



# RAPTOR

50 Size 3D Heli



# MANUAL

ASSEMBLY & MAINTENANCE

## NOTICE

This is an electronic duplicate of the Thunder Tiger Manual for the Raptor 50 V2 kit. In contrast with the Raptor 30 manuals, a Raptor 50 manual has never been made available in electronic form by Thunder Tiger. Therefore this manual was constructed partly by scanning in parts and by manually creating the pages, and partly by copying and modifying the Raptor 30 V2 manual. I did a very careful job in duplicating the manual, but of course I can not assume responsibility in case of errors.

The duplicate has been kept as close as possible to the original manual, but at numerous places errors and typos were corrected. At many places the English text was improved, as well as the layout. Some part numbers have been corrected. A few sentences where correction would need more than changing a few words were left unchanged.

The front page has been recreated in color, where the original manual is all black and white. A colored front page is so much more inviting!

I hope you enjoy the use of this electronic manual.

June 2003  
Wouter Pasman  
Netherlands.

## INTRODUCTION

Congratulations on your purchase of the Thunder Tiger Raptor 50 V2 helicopter. This model was designed and engineered by the World-renowned Mr. Shgetada Taya. It combines elements of his previously successful designs with today's advanced technologies.

Raptor 50: the best 50 class 3-D helicopter is now even better! The Raptor 50 V2 is the cumulating result from all customers' feedback and tremendous research and development effort by the Thunder Tiger design team. The Raptor 50 V2 is more rugged and has even better flying performance than the original successful Raptor 50. The Raptor 50 V2 has the best power-to-weight ratio of any 50 class helicopter on the market. Buckle your seatbelt and get ready for incredibly fast accelerations and climb rate. With the new main rotor, 3-D pilots will enjoy executing crisp maneuvers like Climbing Tic-Toc, Chaos, Death Spirals, and any radical maneuver that pilots can dream of. Key new features include stronger mainframes, bigger fuel tank, reinforced pitch control arm, new main rotor with 6 mm spindle and bigger radial and thrust bearings, and a fresh new look body. The V2 includes a constant drive auto rotation gear for doing aerobatics during autorotation. Beginners and advanced 3-D fliers will be very impressed with the new Raptor 50 V2.

## CONTENTS

Introduction.....	p.1	Assembling Section.....	p.4
Contents.....	p.1	Linkage Set-up Section.....	p.18
Warnings.....	p.1	Blade Modification.....	p.26
Additional Items Needed.....	p.3	Parts List Section.....	p.28
Tools Needed.....	p.3		

## WARNING

This radio controlled helicopter is not a toy. It is a sophisticated piece of equipment and is designed for hobby use only. If not properly assembled and operated, it is capable of causing property damage and bodily harm to both the operator and/or spectators. Thunder Tiger and its duly authorized distributors assume no liability for damage that could occur from the assembly and/or use/misuse of this product.

## AMA INFORMATION

Operating a model helicopter requires a high degree of diligence and skill. If you are a newcomer to the hobby, it is best to seek help and guidance from accomplished model helicopter pilots. This will greatly speed up the learning process and have you flying successfully in a reasonable time. We also would strongly urge you to join the Academy of Model Aeronautics. The AMA is a non-profit organization that provides its members with a liability insurance plan as well as monthly magazine entitled Model Aviation. All AMA charter aircraft clubs require all pilots to hold a current AMA sporting license prior to operation of their models at club fields. For further information, contact the AMA at:

Academy of Model Aeronautics  
5151 East Memorial Drive  
Muncie, IN 47302  
(317) 287-1256

## FLIGHT SAFETY CHECKLIST

1. Make sure both the transmitter and receiver batteries are fully charged prior to operation the helicopter.
2. Make sure all flight controls operate properly prior to flying.
3. Range check the radio before the first flight. The servos must operate properly with the transmitter antenna collapsed at a range of at least 50 ft.(15 meters).
4. Check to make sure there is no radio interference on your radio channel before operating the helicopter.
5. Use only the recommended engine fuel as specified by the engine manufacturer.
6. Make sure the transmitter and receiver are turned on before starting the engine.
7. The engine throttle must be in the idle position before starting the engine.
8. Model helicopter main and tail rotors operate at high RPM. Make sure nothing can come in contact with the rotor blades during flight.
9. After starting the helicopter, maintain a safe distance during the flight.
10. Never operate the helicopter in rain or excessive wind conditions.
11. Always operate and fly your helicopter in a safe and responsible manner.
12. Never fly a model helicopter over other pilots, spectators or cars.

## POST FLIGHT INSPECTION

1. Inspect the model thoroughly to insure no parts have come loose or become damaged during the flight and landing. Replace damaged parts and tighten loose screws before flying again.
2. Pump out any remaining fuel from the fuel tank.
3. Wipe off excess oil and fuel from helicopter body and other exposed parts.
4. Lubricate all moving parts ensures smooth operation for the next time you fly.
5. Store model in a cool, dry place. Avoid storage in direct sunlight or near a source of heat.

Following these few, simple safety rules will allow you to enjoy the thrill of model helicopter flying for many years to come.

**CAUTION:** In the event the model has crashed, inspect the flybar, rotor shaft and the blade spindle to make sure they are not bent at all. If any item is damaged, it must be replaced with a new part to ensure safe operation. Do not glue any broken or damaged plastic part. Do not repair broken rotor blades. Always inspect the following items immediately:

Engine starting shaft.

All the gears.

Main shaft, flybar and blade spindle.

Tail boom and support.

Vertical and horizontal fins.

Tail rotor shaft and control system.

Main and tail rotor blades.

# OTHER ITEMS REQUIRED

## RADIO SET

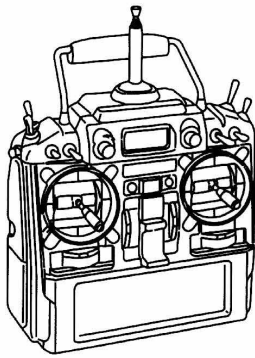

Transmitter  
(helicopter type only  
6 or more channels)

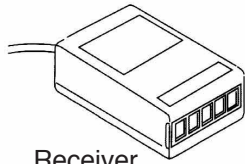

Receiver

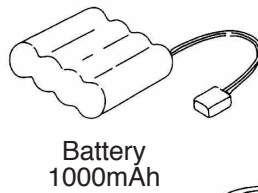

Battery  
1000mAh

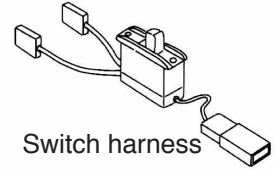

Switch harness

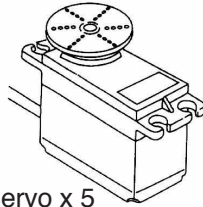

Servo x 5

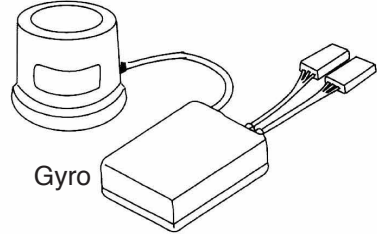

Gyro

## ENGINE

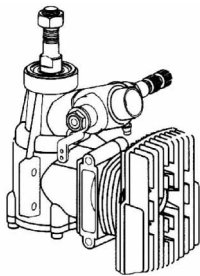

HELI ENGINE(50-size)

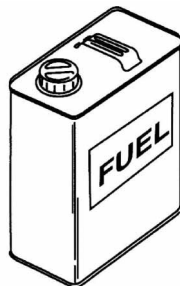

Glow Fuel(15%-30%)

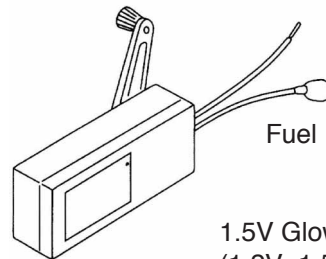

Fuel Pump



Glow Plug

1.5V Glow starter  
(1.2V~1.5V)

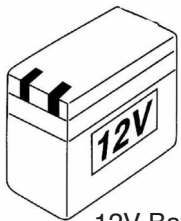
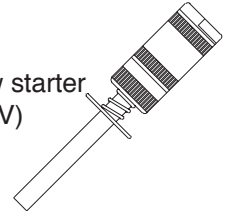

12V Battery

12V Electric starter

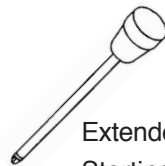
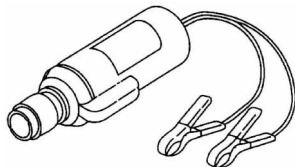

Extended 6mm Hex  
Starting Tool

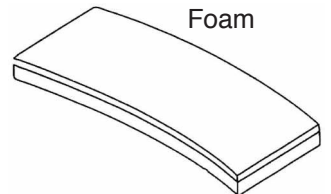

Foam

Remote Glow Plug  
Extension

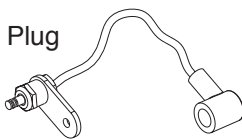

Rubber Band

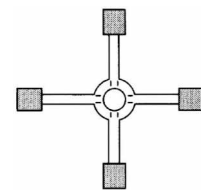
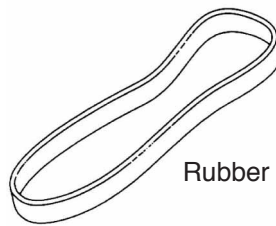

Glow Plug Wrench

# TOOLS REQUIRED FOR ASSEMBLY

Screw Driver

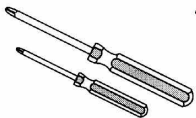

Needle Nose Pliers

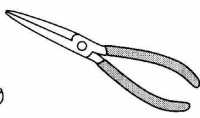

5.5mm Wrench

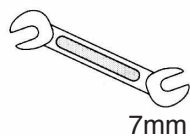

7mm

Ball Link Pliers

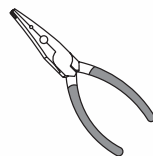

Nipper

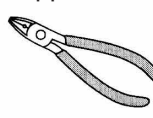

Scissors

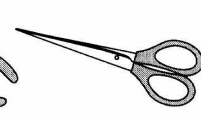

Metric  
4-way Wrench

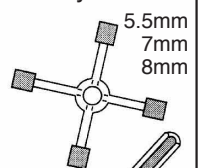

5.5mm  
7mm  
8mm

Hobby Knife



Instant Glue



Blue Locktite



Grease



Epoxy

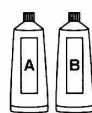

Hex Wrench

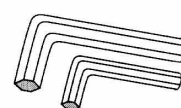

5.5mm  
7mm  
8mm  
10mm

Socket Drivers



# ASSEMBLING SECTION

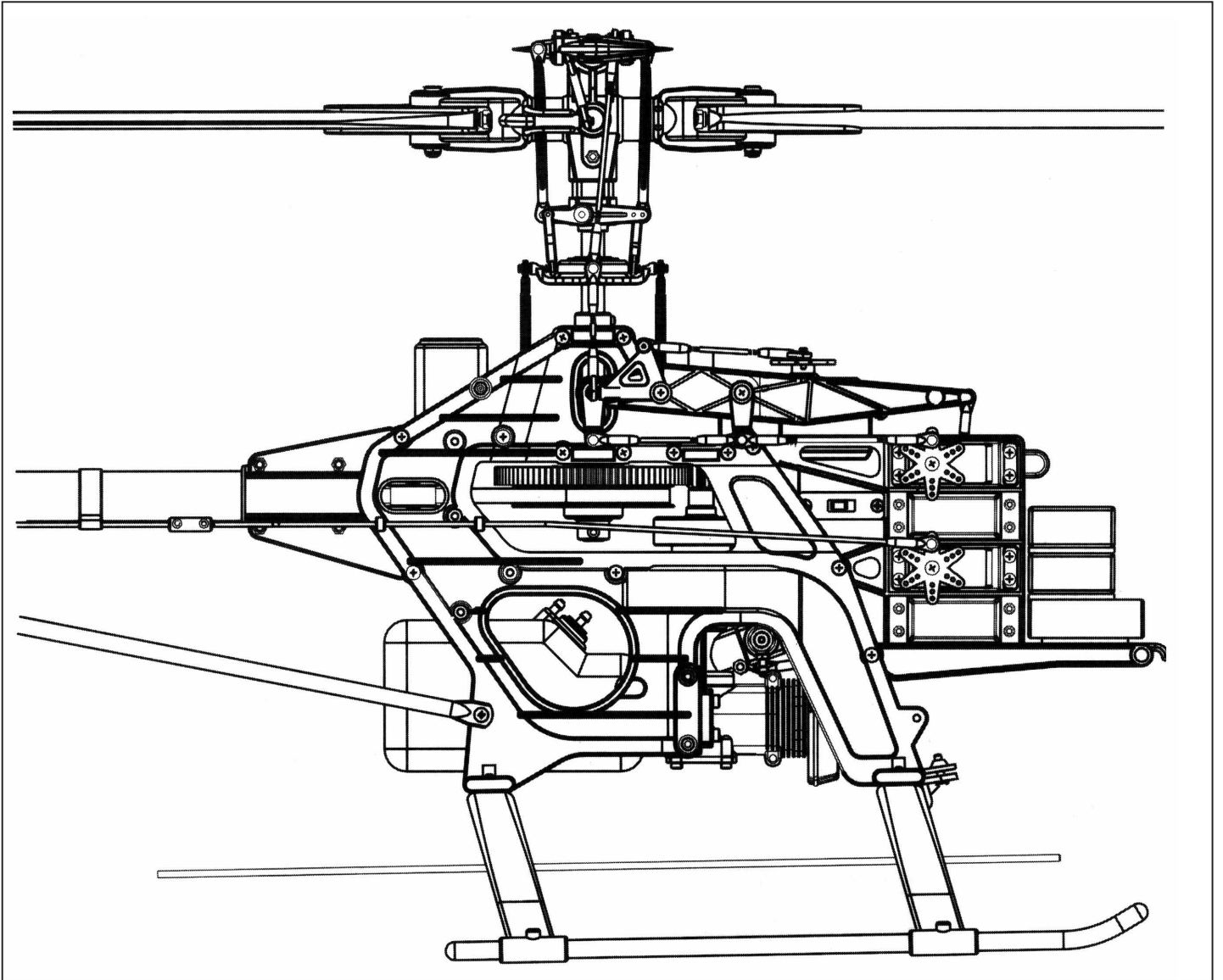

Most parts in the Raptor kit are packed according to the assembly steps. The part number and quantity contained in each step are always shown in the square box on each page. Do not open all the bags at once. Open only the bag that is needed for the current assembly step.

# ① Fuel Tank Assembly

Note: After assembly, check to make sure the Fuel Tank clunk can move from top to bottom without touching the back of tank. Also, a fuel filter (available from any hobby shop, TTR1164) should be placed between the fuel tank and the carburetor.

To Header Tank ←  
Connect the fuel tube to header tank  
(See Page 13 Step. 15)

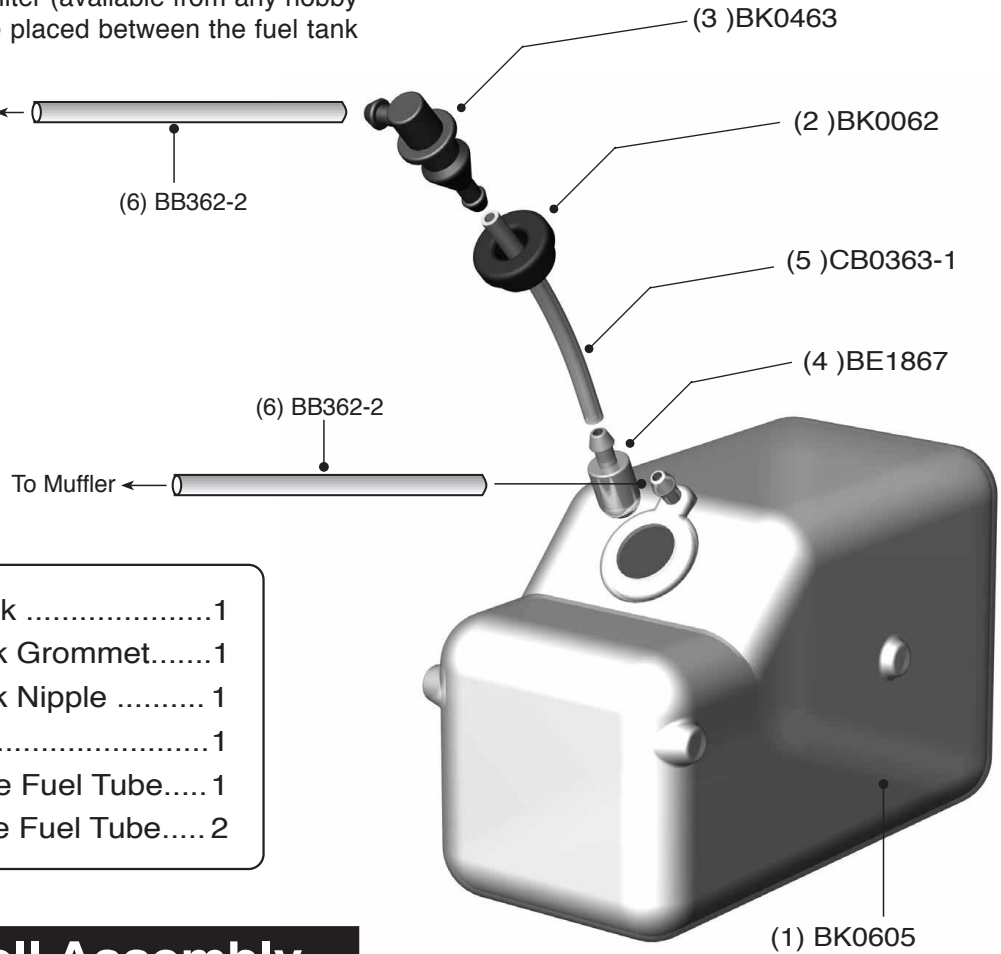

- (1)BK0605 Fuel Tank ..... 1
- (2)BK0062 Fuel Tank Grommet..... 1
- (3)BK0463 Fuel Tank Nipple ..... 1
- (4)BE1867 Clunk..... 1
- (5)CB0363-1 Silicone Fuel Tube..... 1
- (6)BB0362-2 Silicone Fuel Tube..... 2

# ② Clutch Bell Assembly

- (1) HMV1680 Bearing (d8xD16xW5)..... 1
- (2) HMV1260Y Bearing (d6xD12xW4)... 1
- (3) BK0591 Clutch Bell..... 1
- (4) BK0624 Drive Gear(Pinion 10T)..... 1
- (5) BK0590 Clutch Liner..... 1

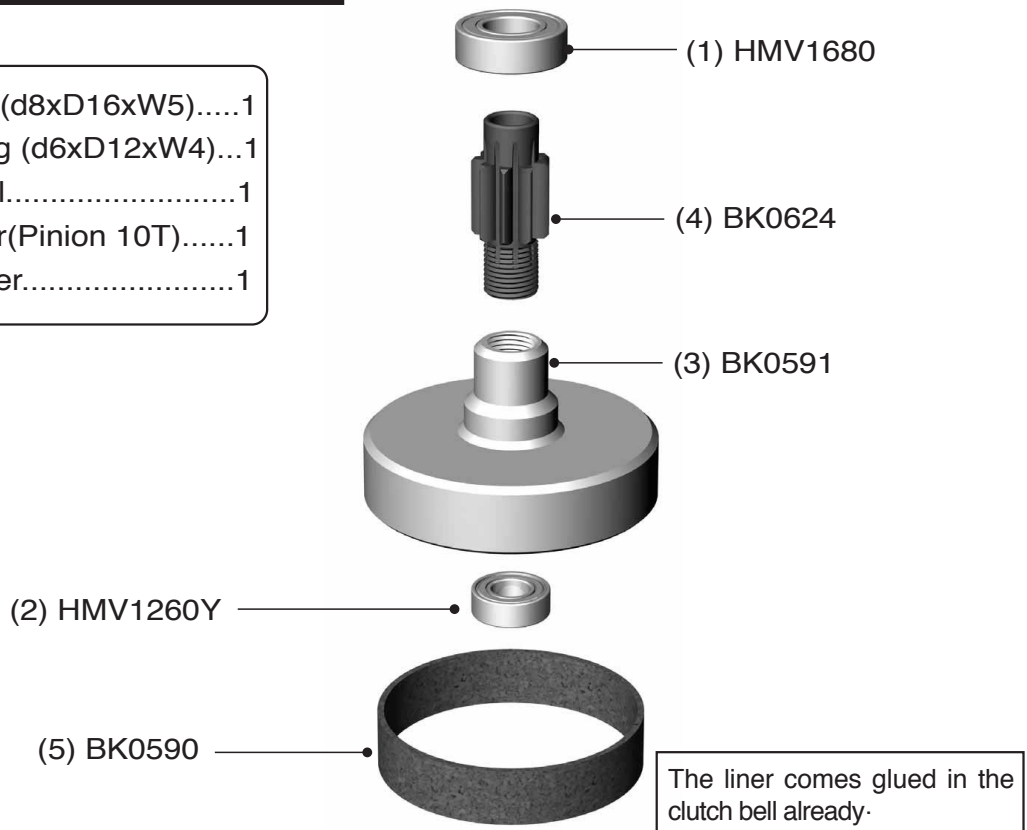

### ③ Main Frame Assembly-Part1

Please insert the frame spacers, bearings, pulley and parts in the frames according the drawing below. Tighten the screws snugly, but do not over torque them which could strip the plastic.

Insert starter shaft through the center of the clutch bell assembly, through the top starter shaft bearing and into the starter coupling. Secure with the two set screws. Make sure this is tightly secured.

(1) HSE3-12B Self Tapping Screw (M3x12)..	30	(10) BK0600 Main Frame Right Side.....	1
(2) HMV696Z Bearing (d6xD15xW5).....	1	(11) BV0035 Guide Pulley.....	2
(3) HMV6800 Bearing (d10xD19xW5).....	2	(12) BK0036 Pulley Collar.....	4
(4) BK0059 Frame Spacer (S).....	8	(13) BK0592 Starter Shaft.....	1
(5) BK0058 Frame Spacer (L).....	4	(14) BK0594 Starter Coupling.....	1
(6) HME4-5B Set Screw (M4x5).....	2	(15) Fuel Tank Assembly	
(7) BK0081 Pin.....	2	(16) Clutch Assembly	
(8) BK0057 Servo Frame.....	1	(17) HMS5 E-CLIP.....	1
(9) BK0599 Main Frame Left Side.....	1	(18) BK0584 Thrust Washer.....	1

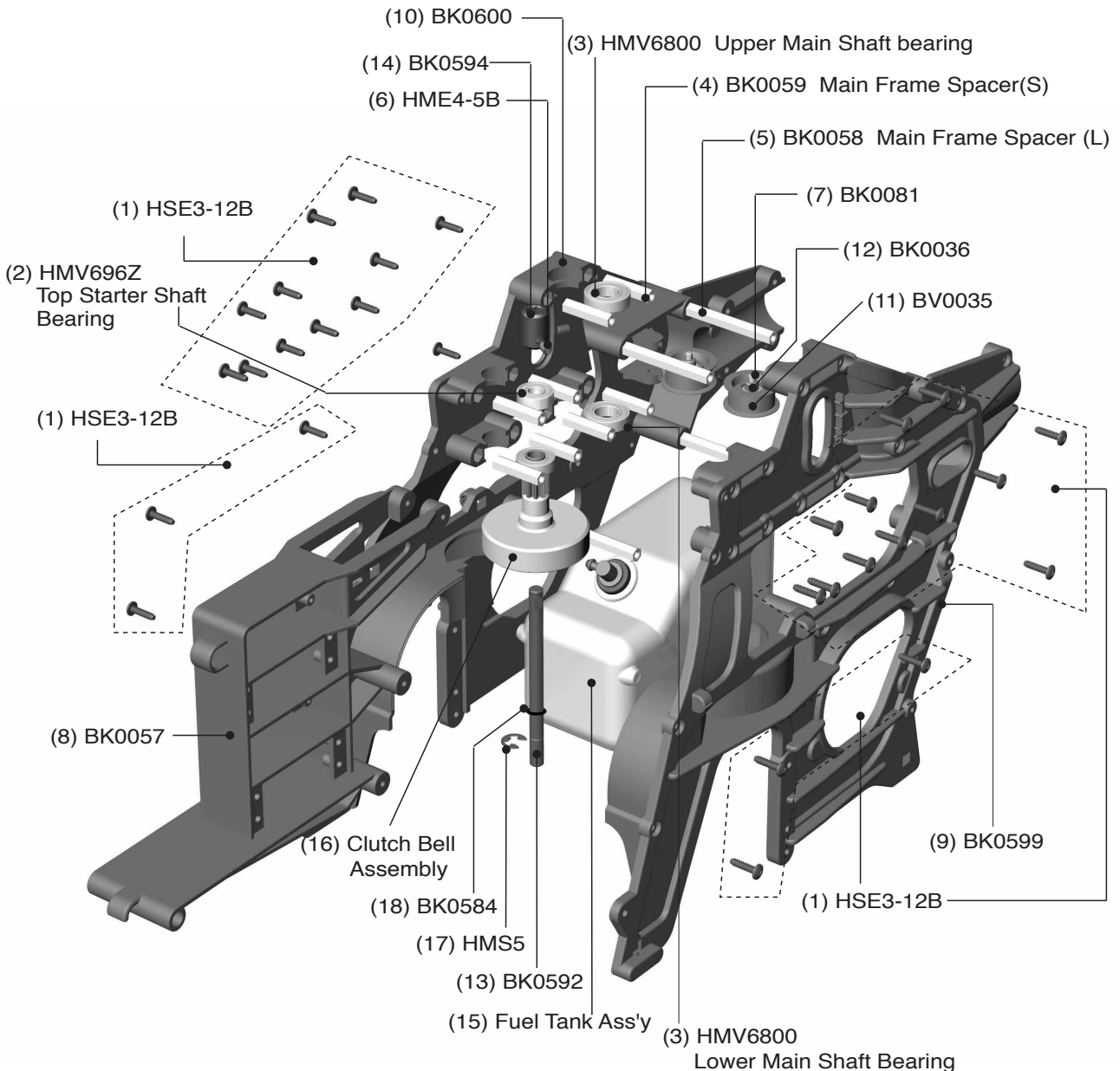



## ④ Main Drive Gear Assembly

- (1) HMC3-8B Socket Screw (M3x8)..... 4
- (2) HMQ14 Snap Ring..... 2
- (3) BV0033 One Way Clutch Housing.....1
- (4) BK0148 Main Spur Gear 85T.....1
- (5) BK0610 Autorotation Tail Drive Pulley ..... 1
- (6) BK0034 One Way Clutch Shaft.....1

Add a drop of Blue Locktite on the thread of each of these four screws.

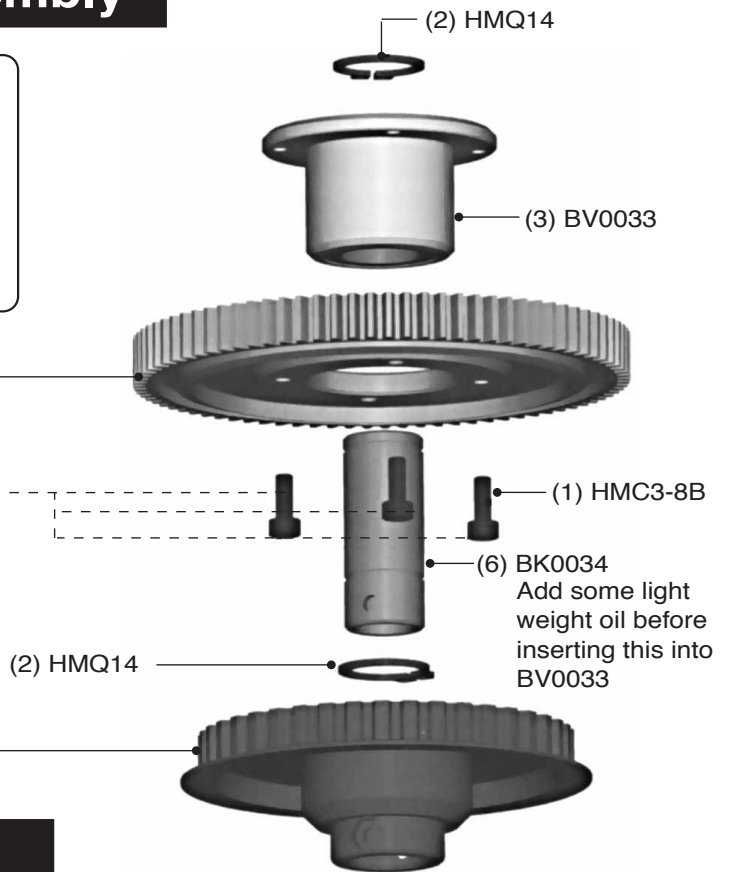

## ⑤ Washout Assembly

- (1) HMJ2-10N Self Tapping Screw(M2x10).. 2
- (2) HMC3-10B Socket Screw (M3x10)..... 2
- (3) HMV740ZZ Bearing (d4xD7xW2.5)..... 4
- (4) BK0077 Collar ..... 2
- (5) BK0079 Pin..... 2
- (6) BK0075 Linkage Ball..... 2
- (7) BK0015 Flybar Control Lever..... 2
- (8) BK0016 Washout Linkage ..... 2
- (9) BK0014 Washout Base.....1

Make sure Linkage Balls are attached to the inside hole of each stabilizer control lever.

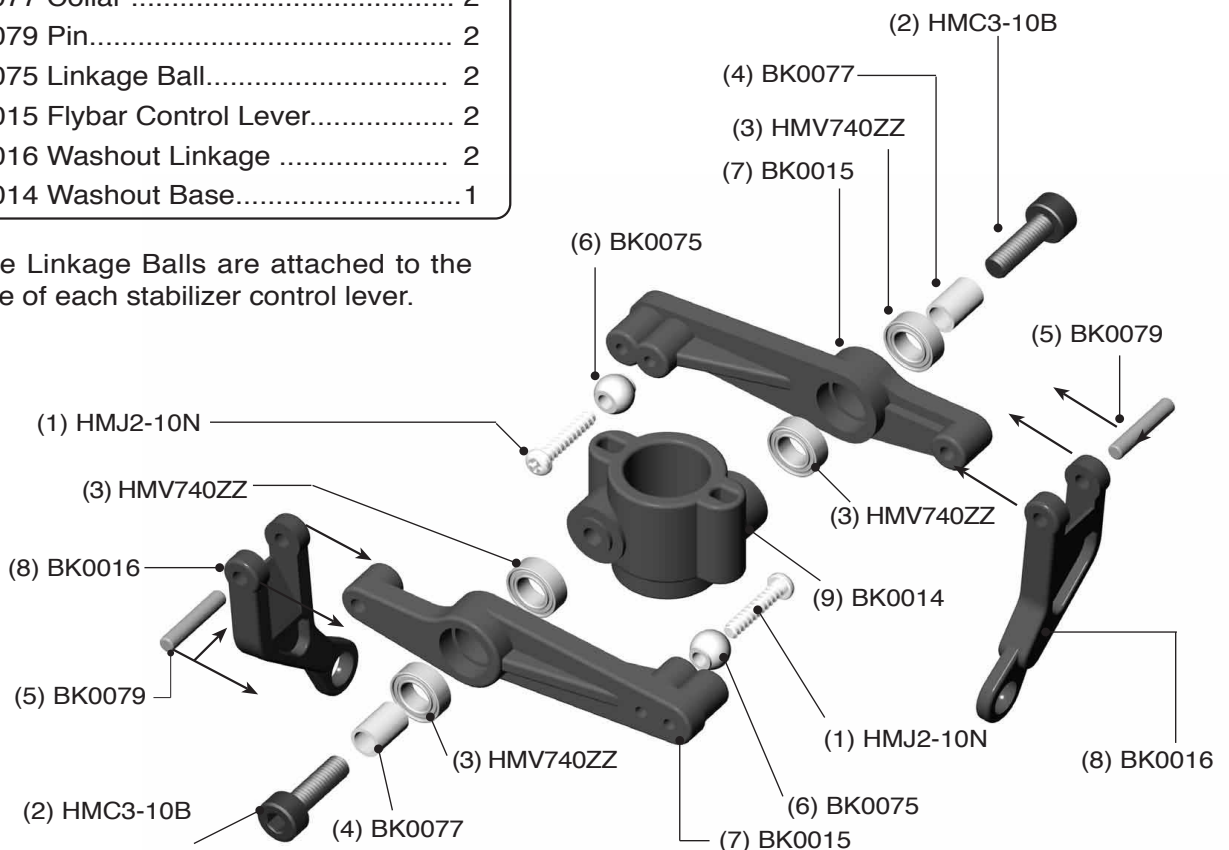

## ⑥ Main Frame Assembly-Part2

Add a drop of CA to the two screws at the pivoting point of the collective pitch control arm.  
Attach the linkage rod to the parallel elevator linkage balls.

(1) HSE3-18B Self Tapping Screw(M3x18)....4	(12) BK0084 Pin ..... 2
(2) HSE3-12B Self Tapping Screw(M3x12)... 1	(13) BK0075 Linkage Ball.....8
(3) HMJ3-22B Self Tapping Screw(M3x22)....1	(14) BK0023 Elevator Control Arm Link..... 2
(4) HMJ2-14N Self Tapping Screw(M2x14)... 1	(15) BK0018 Elevator Control Arm..... 1
(5) HMJ2-10N Self Tapping Screw(M2x10)... 6	(16) BK0020 Elevator Arm Control Shaft..... 1
(6) HMV1280 Bearing (d8xD12xW3.5)..... 2	(17) BK0022 Aileron Control Lever..... 2
(7) HMV740ZZ Bearing (d4xD7xW2.5)..... 6	(18) BK0019 Elevator Arm Parallel Lever..... 1
(8) HMV840ZZ Bearing (d4xD8xW3)..... 2	(19) BK0086 Ball Link.....2
(9) BK0076 Collar..... 3	(20) BK0093 Linkage Rod ..... 1
(10) BK0078 Collar ..... 2	(21) BK0021 Elevator Control Lever..... 1
(11) BK0088 Flat Washer ..... 1	(22) BK0017 Collective Pitch Control Arm..... 1

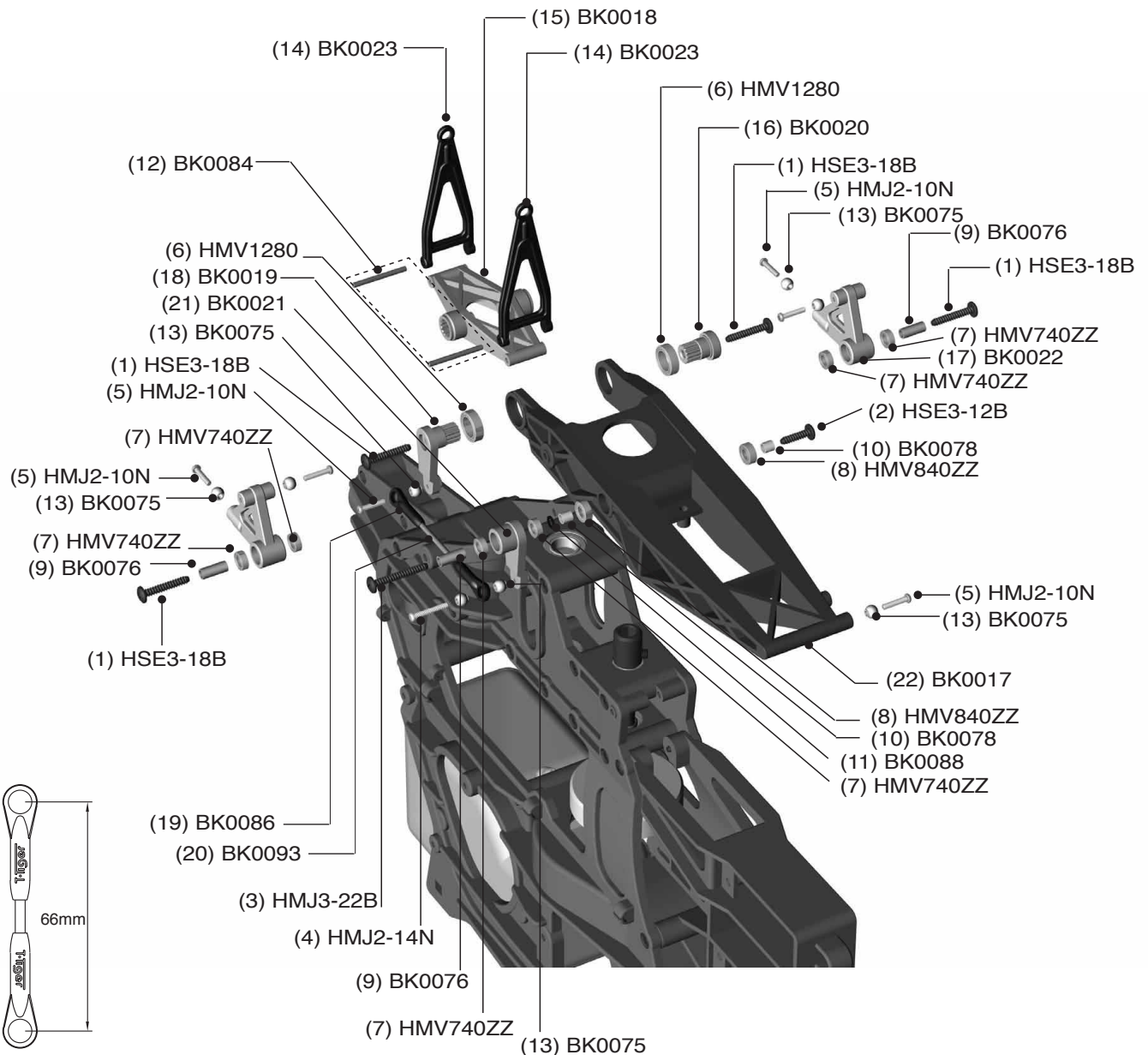

**Warning, do not over-torque the self-tapping screws.**

## ⑦ Main Frame Assembly-Part3

Insert Main Shaft through the shaft bearings making sure that the end with the holes closest to the end is pointed down. Next, slide main gear assembly into position on the shaft and line up the holes in the main shaft with the holes in one way clutch shaft of the main gear assembly. Insert the socket head screw and secure with the lock nut. Next, slide on the mainshaft lock ring on top of the main shaft bearing and secure with the two set screws. Then slide on the swash plate assembly and attach the elevator and aileron control linkages to the outside swash plate linkage balls. Next, slide on washout assembly and attach washout linkage to the inner linkage balls of the swash plate.

- (1) BK0616 Socket Screw(M3x20)..... 1
- (2) HMM3Z Lock Nut (M3)..... 1
- (3) HME4-5B Set Screw (M4x5)..... 2
- (4) BK0086 Ball Link ..... 4
- (5) BK0092 Linkage Rod ..... 2
- (6) BK0030 Main Shaft Lock Ring..... 1
- (7) BK0029 Main Shaft ..... 1
- (8) Wash Out Assembly
- (9) BV0092 Swash Plate Assembly..... 1
- (10) Main Gear Assembly

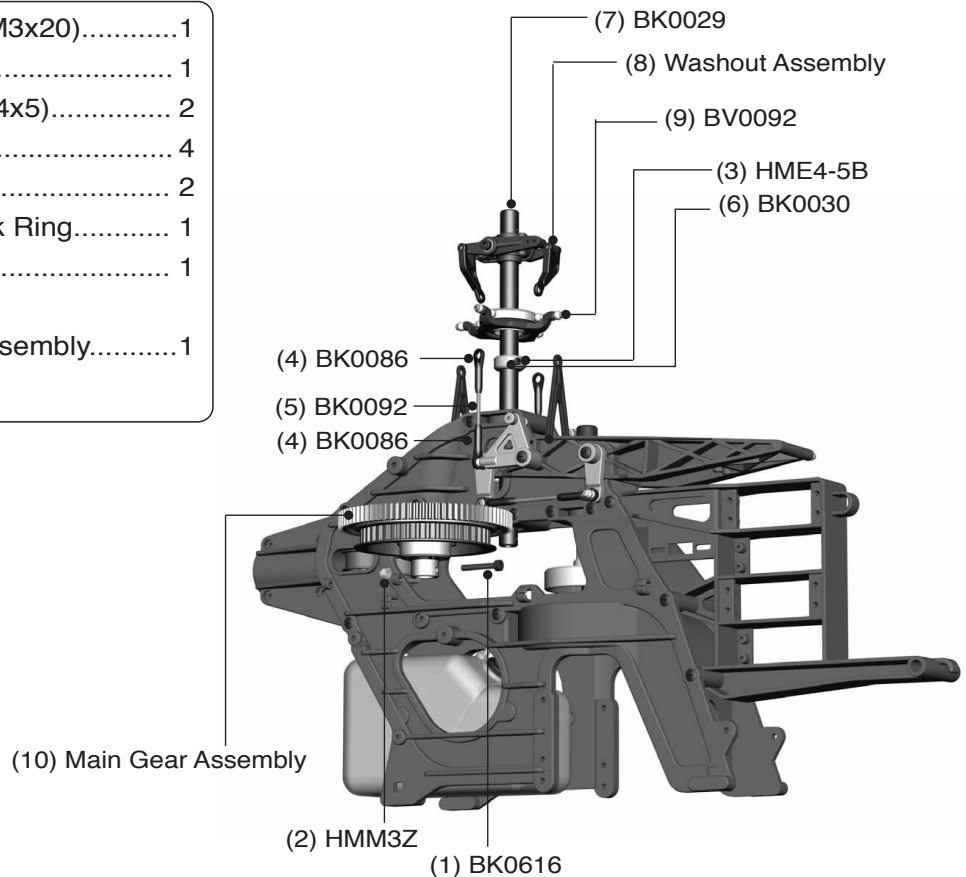
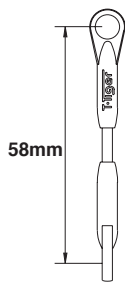

## ⑧ Engine Assembly

Note: A piston lock (TTR1166P) purchased from your dealer will make this a much easier task. You must replace the standard throttle arm w/the extended throttle arm and attach the linkage ball.

- (1) HMC3-10B Socket Screw(M3x10)..... 2
- (2) BV0589 Clutch Shoe..... 1
- (3) BV0143 Cooling Fan..... 1
- (4) No.9605 TT PRO-50H(R) Engine..... 1
- (5) BK0170 Shim..... 1

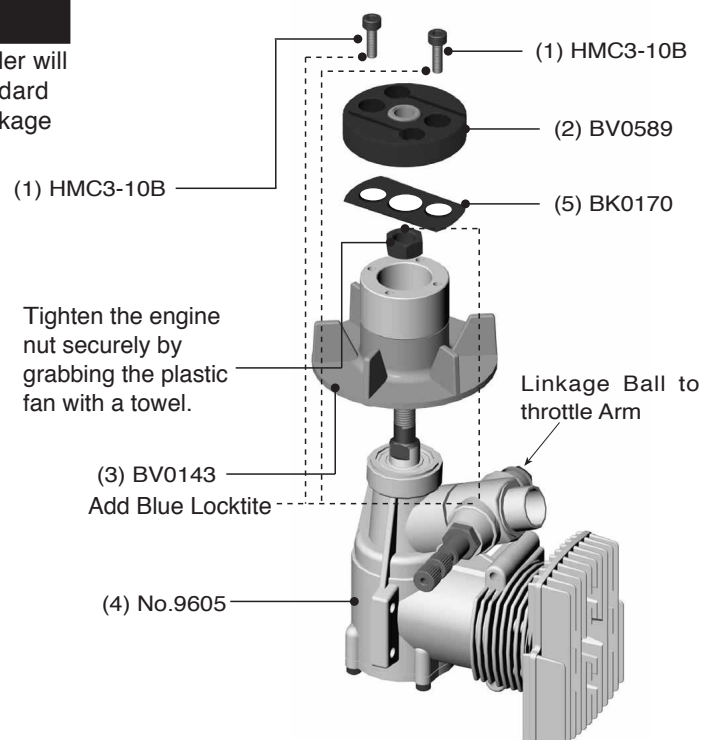

## ⑨ Main Frame Assembly-Part4

Add blue Loctite to all metal to metal screw surfaces.  
After installing the engine, connect the silicone fuel tube to the carburetor and muffler.

- |                                       |   |
|---------------------------------------|---|
| (1) HMC3-14B Socket Screw(M3x14)..... | 8 |
| (2) HMC3-35B Socket Screw(M3x35)..... | 2 |
| (3) BK0087 Flat Washer.....           | 4 |
| (4) BK0144 Engine Mount.....          | 1 |
| (5) BV0172 Muffler .....              | 1 |
| (6) Engine Assembly                   |   |
| (7) BA1579 Muffler Gasket.....        | 1 |
| (8) BK0179 Spacer.....                | 2 |

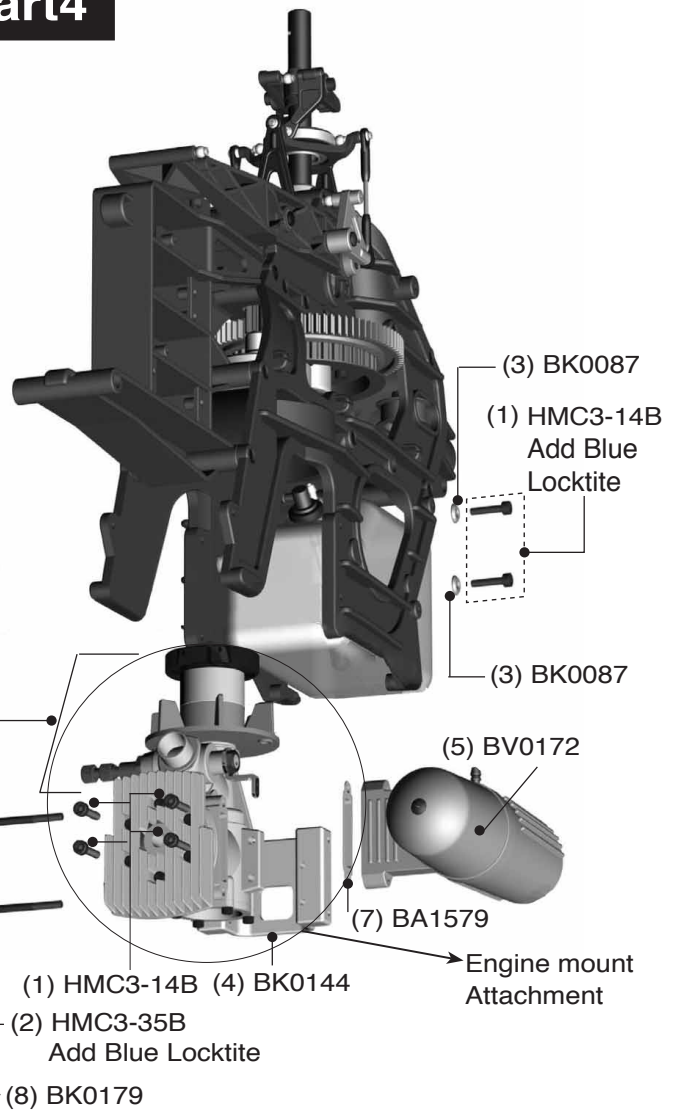

### Engine Mount Notes:

The engine mount furnished will accommodate the Thunder Tiger 46H, 50H, and the other heli engines. If you are installing a Thunder Tiger engine, you will find the mount is wider than the engine crankcase. Two spacers are furnished to accurately locate the engine while bolting it in place. Remove these spacers after installation.

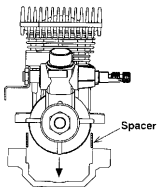

**Step1**  
Install the engine and spacers into the engine mount.

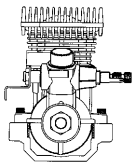

**Step2**  
Install the 4 mount screws and make sure the screws are tightened firmly.

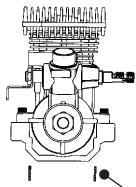

**Step3**  
Remove the spacers.

## ⑩ Landing Skid Assembly

- |  |   |
|--|---|
| (1) HSE3-18B Self Tapping Screw(M3x18).4 |   |
| (2) HME4-5B Set Screw(M4x5).....         | 4 |
| (3) BK0066 Skid Brace.....               | 2 |
| (4) BK0064 Skid Pipe.....                | 2 |
| (5) BK0065 Skid Pipe End Cap.....        | 4 |
| (6) BK0525 Carbon Base Plate.....        | 1 |

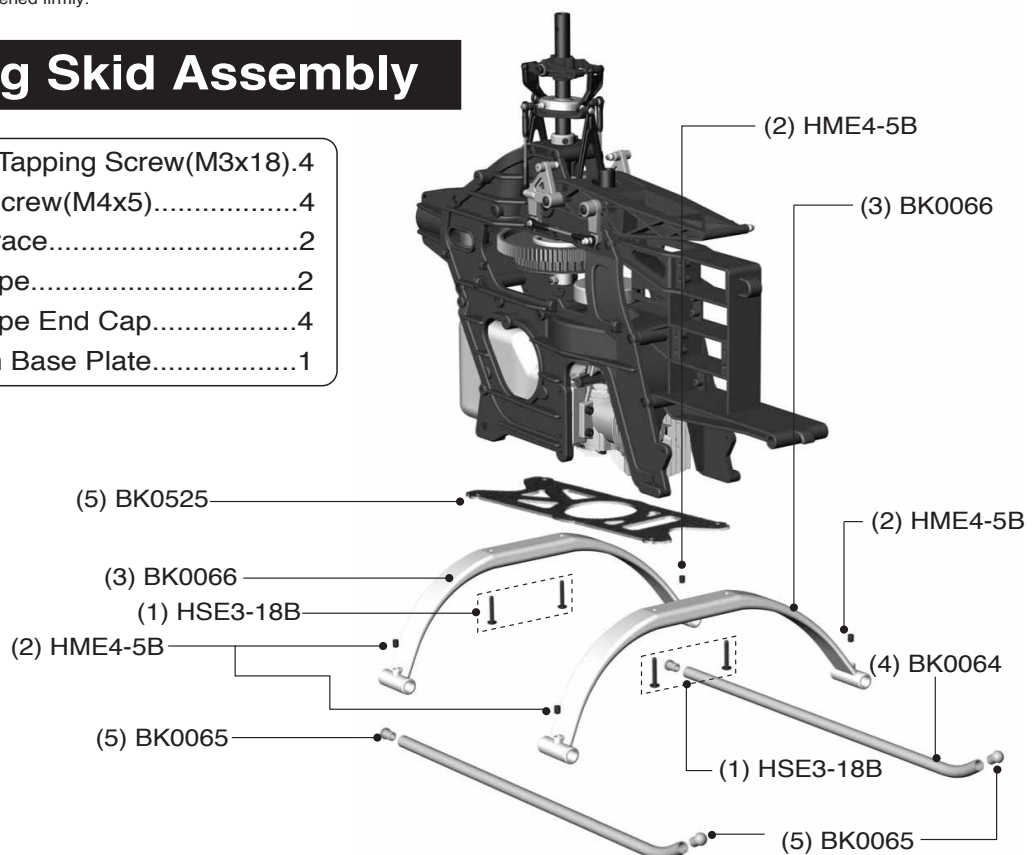



# 11 Main Rotor Head Assembly

Assembly Hint: Start from the bottom of the main Rotor Hub and work your way up to the flybar assembly. When screwing on the flybar paddles to the flybar, stop when you can see the rod in the window of the paddle. Then, lay the assembly on a flat surface and align the paddles so they are exactly parallel. Insert and tighten the set screws. Attach the flybar control rod to the flybar control arm and use the Double Link to connect the mixing lever (short side) to the Main rotor Pitch Housing.

(1) HMC3-14B Socket Screw(M3x14).....	2	(12) HMV1360Z Bearing (d6xD13xW5).....	4	(23) BK0596 Main Rotor Pitch Housing.....	2
(2) HMC3-8B Socket Screw(M3x8).....	2	(13) BK0076 Collar.....	2	(24) BK0583 Feathering Shaft.....	1
(3) HMJ2-10N Self Tapping Screw(M2x10)....	8	(14) BK0078 Collar.....	2	(25) BK0007 Flybar Control Rod.....	2
(4) HME4-5B Set Screw(M4x5).....	2	(15) BK0581 Flap Collar.....	2	(26) BV0085 Double Link .....	2
(5) HME3-10B Set Screw(M3x10).....	2	(16) BK0088 Flat Washer.....	2	(27) BK0586 Flap Damper.....	2
(6) BK0435 Washer (d4xD11xW1.7).....	2	(17) BK0067 Flybar Paddle.....	2	(28) BK0012 Pin.....	2
(7) HMC4-8B Socket Screw (M4x8).....	2	(18) BK0010 Flybar Rod.....	1	(29) BK0587 Main Rotor Hub Pin.....	1
(8) HMV830ZZ Bearing (d3xD8xW4).....	2	(19) BK0002 Flybar Control Arm.....	2	(30) BK0595 Main Rotor Hub.....	1
(9) HMV740ZZ Bearing (d4xD7xW2.5).....	4	(20) BK0005 Flybar Arm Bushing.....	2	(31) BK0075 Ball Link.....	8
(10) HMV840ZZ Bearing (d4xD8xW3).....	2	(21) BK0004 Flybar Seesaw Hub.....	1	(32) BK0584 Thrust Washer.....	2
(11) HMX0612 Thrust Bearing.....	2	(22) BK0006 Mixing Lever.....	2		

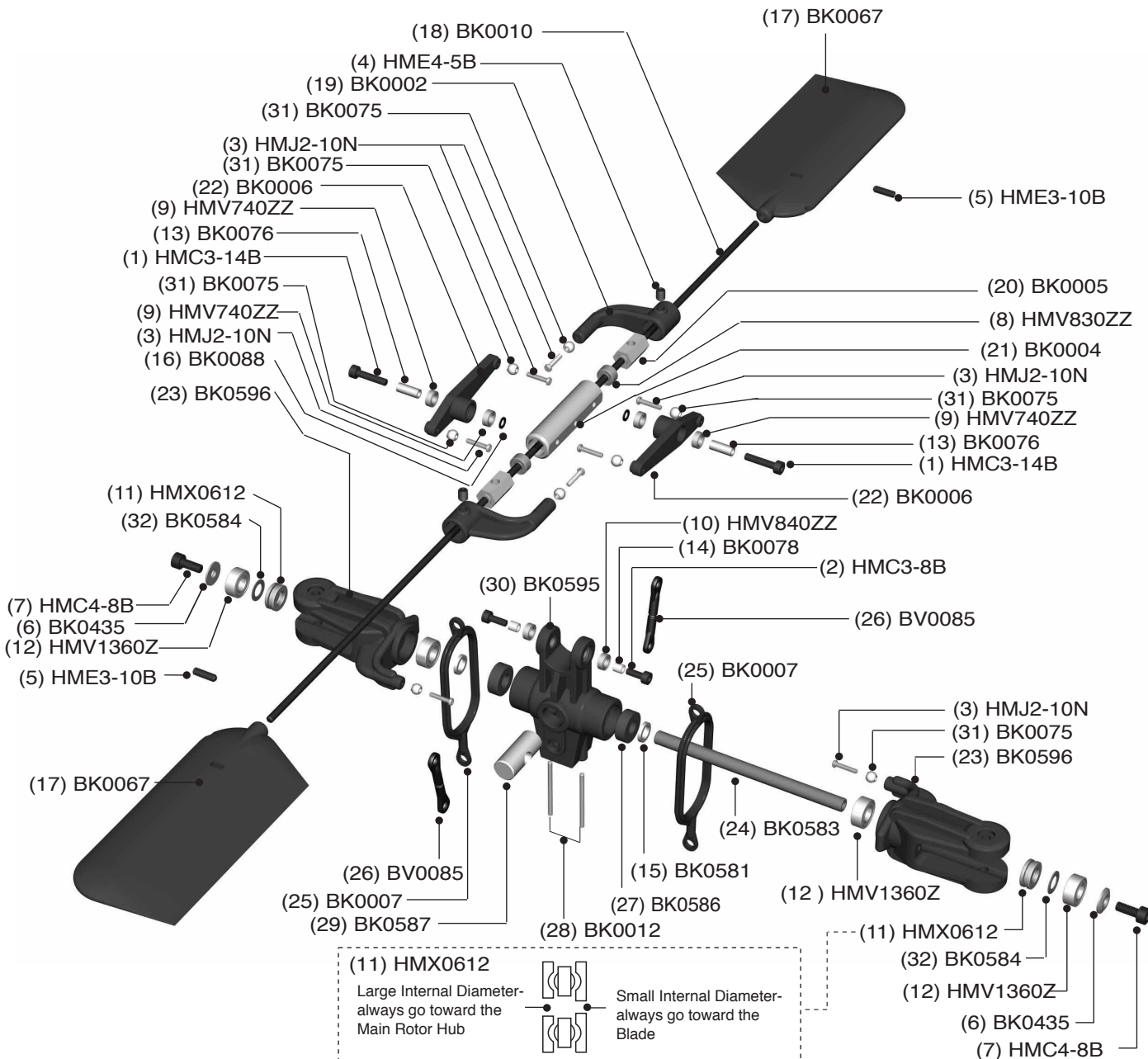



## 12 Main Frame Assembly-Part5

Slide the main Rotor assembly over the main shaft and align the two pins to slide in the washout assembly. Make sure the holes in the main shaft line up with the holes in the main rotor head. Insert the socket screw and secure with locknut. Attach the ball linkage rods to the long end of the mixing lever and to the remaining inside linkage balls of the swash plate.

- |                                       |   |
|---------------------------------------|---|
| (1) BK0616 Socket Screw(M3x20).....   | 1 |
| (2) HMM3Z Lock Nut(M3).....           | 1 |
| (3) HME3-18B Set Screw(M3x18).....    | 1 |
| (4) BK0095 Linkage Rod.....           | 2 |
| (5) BK0086 Ball Link.....             | 4 |
| (6) BK0626 Canopy Retaining Post..... | 2 |
| (7) Main Rotor Head Assembly          |   |

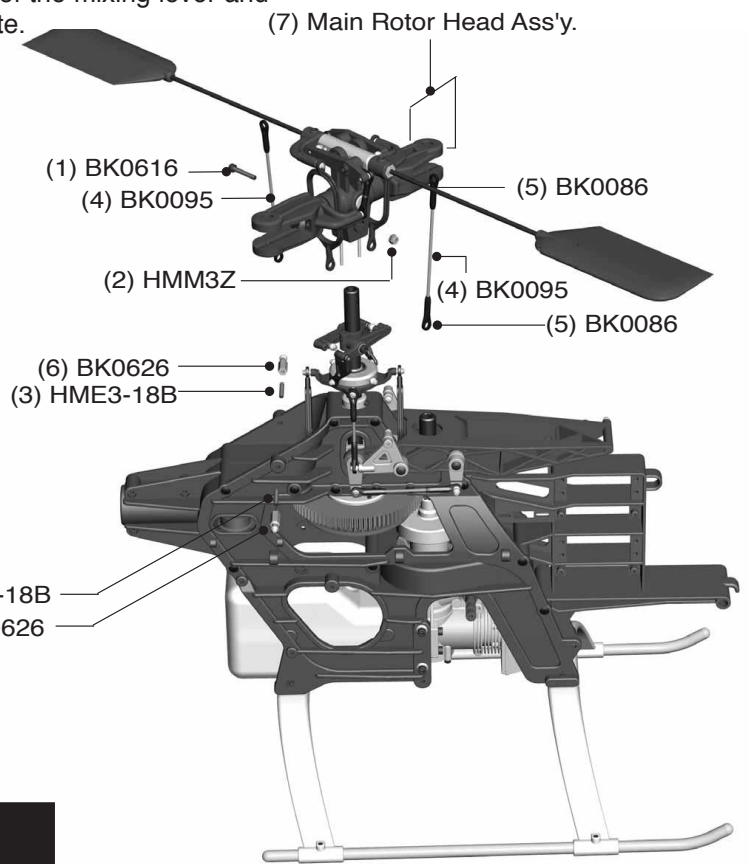
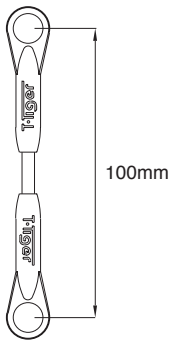

## 13 Tail Unit Assembly

Assembly Tip: Work from left to right when assembling the parts. The tail pitch control lever screws into the arm extending from the tail unit housing.

- |   |  |   |
|---|--|---|
| (1) HSE3-18B Self Tapping Screw(M3x18).1  | (21) BK0027 Tail Pitch Control Slider.....       | 1 |
| (2) HMC2610B Socket Screw(M2.6x10).....   | (22) BK0028 Tail Pitch Control Slide Bushing.... | 1 |
| (3) HSE2-10B Self Tapping Screw(M2x10).2  | (23) BK0053 Tail Rotor Shaft.....                | 1 |
| (4) HMF2-8N Screw(M2x8).....              | (24) BK0050 Tail Pulley.....                     | 1 |
| (5) HME3-18B Set Screw(M3x18).....        | (25) BK0051 Tail Pulley Flange.....              | 1 |
| (6) HMM3Z Lock Nut(M3).....               | (26) BK0024 Tail Pitch Control Lever.....        | 1 |
| (7) HMV1150X Bearing (d5xD11xW5).....     | (27) BK0047 Tail Unit Housing (R).....           | 1 |
| (8) HMV1050 Bearing (d3xD8xW4).....       | (28) BK0075 Link Ball.....                       | 2 |
| (9) HMV1060 Bearing (d6xD10xW3).....      | (29) HMM26B Lock Nut(M2).....                    | 4 |
| (10) HMV740ZZ Bearing (d4xD7xW2.5)...     | (30) HME3-4B Set Screw(M3x4).....                | 1 |
| (11) BK0082 Collar(2x3x4).....            |  |   |
| (12) BK0076 Collar(3x4x10).....           |  |   |
| (13) BK0083 Pin(2x9).....                 |  |   |
| (14) BK0414 Pin(2x12).....                |  |   |
| (15) BK0088 Flat Washer.....              |  |   |
| (16) BK0302-1 Tail Pitch Housing (A)..... |  |   |
| (17) BK0303-1 Tail Pitch Housing (B)..... |  |   |
| (18) BK0307 Tail Rotor Hub.....           |  |   |
| (19) BK0026 Tail Pitch Control Link.....  |  |   |
| (20) BK0025 Tail Pitch Control Fork.....  |  |   |

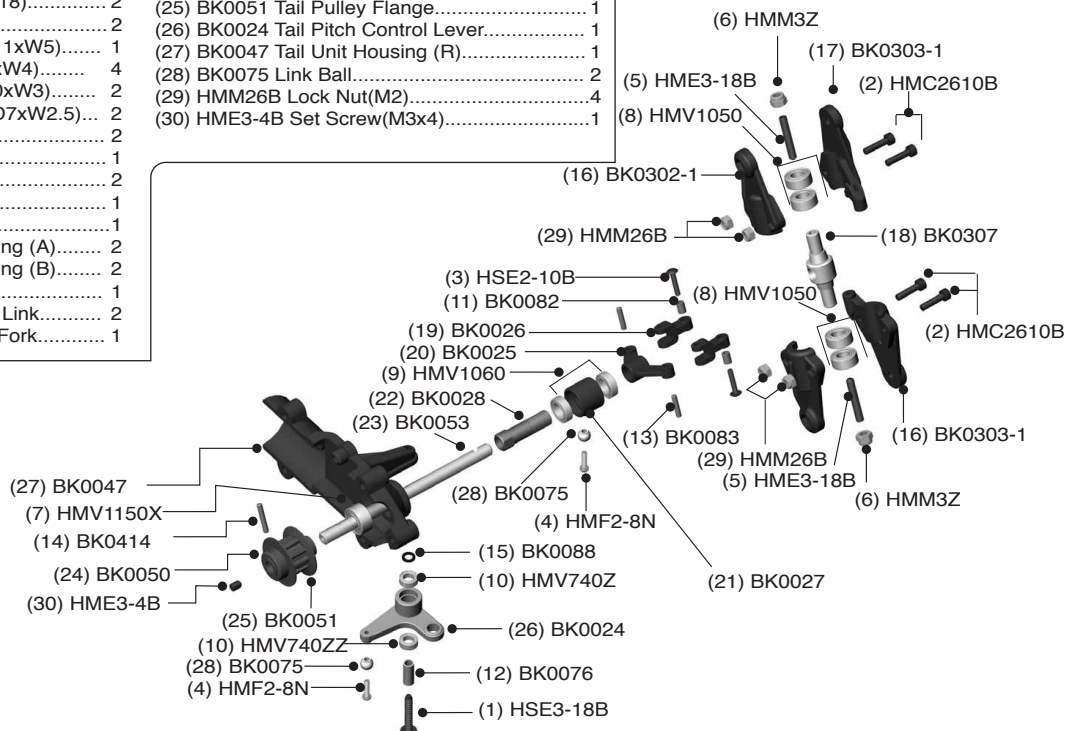

## 14 Tail Boom Assembly

Assembly Tip: Slide the 3 rod guides onto the boom and space them out evenly as shown. Then slide the tail linkage rod into the rod guides. Next, insert the tail rotor drive belt into the boom so that it comes out of both ends. Place drive belt over tail drive pulley and complete balance of tail boom assembly. Remember to connect the tail linkage rod to the tail control lever.

- (1) HMC3-20B Socket Screw(M3x20).. 4
- (2) HMC3-25B Socket Screw(M3x25).. 2
- (3) HSE3-12B Self Tapping Screw(M3x12).. 4
- (4) HMM3Z Lock Nut(M3)..... 6
- (5) HMV1150X Bearing (d5xD11xW5).. 1
- (6) BK0046 Tail Unit Housing (L)..... 1
- (7) BK0071 Vertical Fin..... 1
- (8) BK0069 Stabilizer Fin..... 1
- (9) BK0070 Stabilizer Fin Bracket..... 1
- (10) BK0524 Tail Support Rod..... 2
- (11) BK0173 Tail Boom..... 1
- (12) BK0091 Rod Guide..... 3
- (13) BK0174 Tail Rotor Drive Belt..... 1
- (14) BK0175 Tail Linkage Rod..... 1
- (15) BK0086 Ball Link..... 1
- (16) BV0052 Tail Idle Pulley..... 1
- (17) Tail Unit
- (18) HMJ2-8N Self Tapping Screw(M2x8).. 4
- (19) BK0447 Tail Support Rod End..... 4

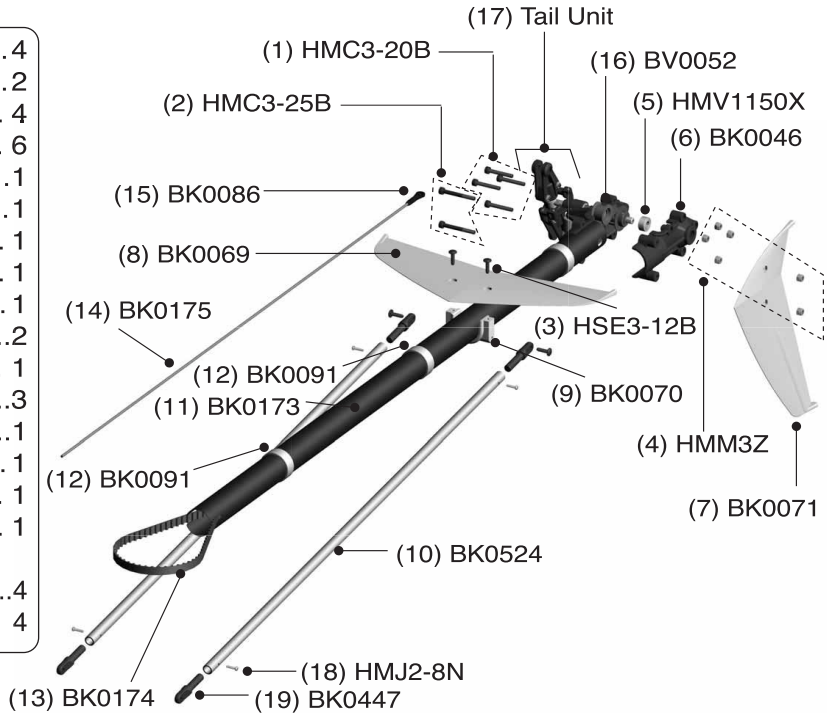

## 15 Main Frame Assembly-Part6

Insert the four 3x20 socket screws into the tail base of the Main Frame and secure with lock nuts. **Do not tighten at this point.** Hold the tail boom in one hand and hook your index finger on your free hand through the exposed loop of the tail rotor drive belt. Hold it so the belt is vertical and parallel to the tail drive pulley.

ⓘ Boom Drive belt

Important: Next, rotate the belt 90-degree counter clockwise.

⊖ 90-degree

- (1) HMC3-14B Socket Screw(M3x14)..... 2
- (2) HMC3-20B Socket Screw(M3x20)..... 4
- (3) HSE3-12B Self Tapping Screw(M3x12).... 2
- (4) HMM3Z Lock Nut(M3)..... 6
- (5) BK0068 Tail Rotor Blade..... 2
- (6) Tail Assembly
- (7) BV0502 Header Tank..... 1
- (8) BK0506 Tank Mount..... 2
- (9) BK0102 Rubber Grommet..... 1
- (10) BK0087 Washer..... 1
- (11) HMC3-14B Socket Screw (M3x14).... 1

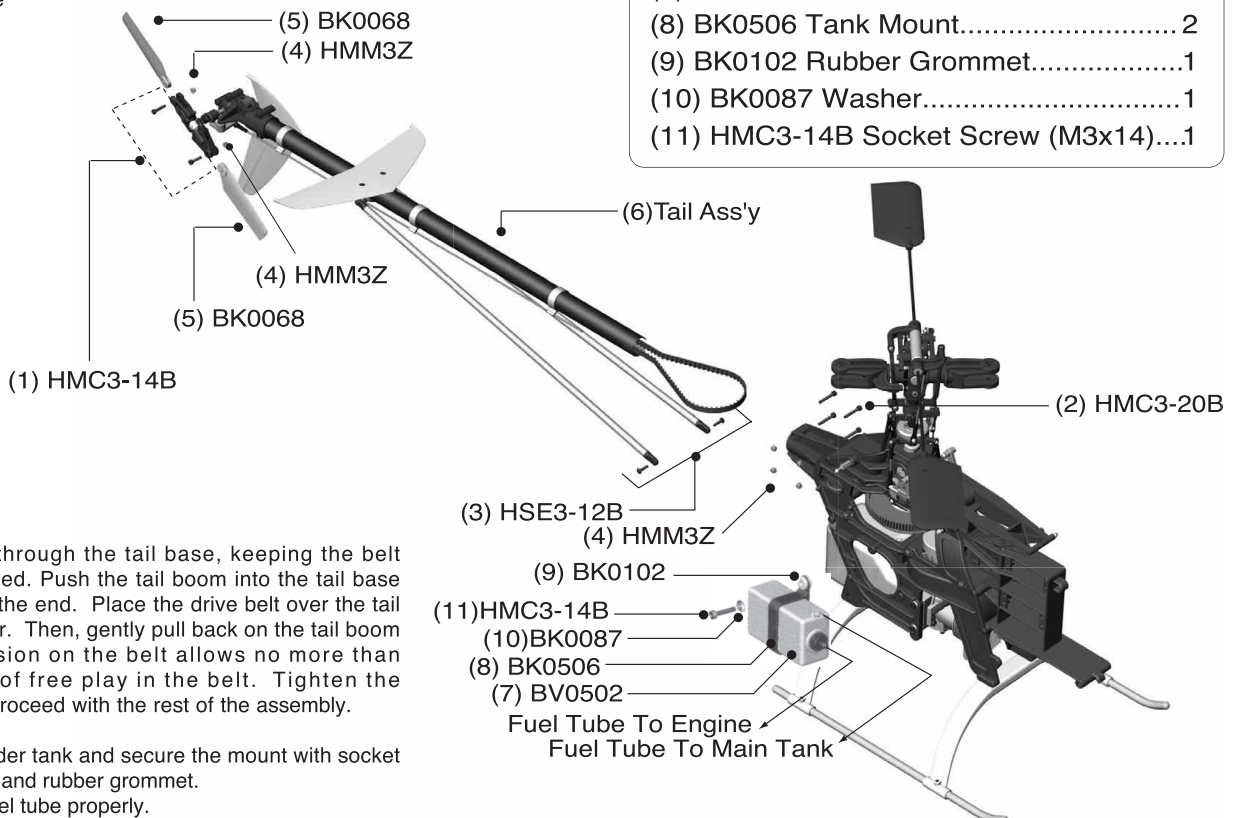

Pull the belt through the tail base, keeping the belt correctly aligned. Push the tail boom into the tail base all the way to the end. Place the drive belt over the tail drive spur gear. Then, gently pull back on the tail boom until the tension on the belt allows no more than 5mm(3/16") of free play in the belt. Tighten the locknuts and proceed with the rest of the assembly.

Install the header tank and secure the mount with socket screw, washer and rubber grommet. Connect the fuel tube properly.

# 16 Servo Installation-Part1

Assembly Tip: Remove all the servo wheels prior to attaching the steel linkage balls. Make sure all linkages are the correct length.

- (1) HSE2612N Self Tapping Screw(M2.6x12)....12
- (2) HMF2-8N Screw(M2x8)..... 4
- (3) HML2 Hex Nut(M2)..... 4
- (4) HME4-5B Set Screw(M4x5)..... 2
- (5) BK0093 Linkage Rod..... 2
- (6) BK0094 Linkage Rod..... 1
- (7) BK0100-1 Linkage Rod..... 1
- (8) BK0105 Tail Control Rod Joint..... 1
- (9) BK0075 Linkage Ball..... 4
- (10) BK0086 Ball Link..... 7
- (11) BK0104 Servo Mounting Plate.....10

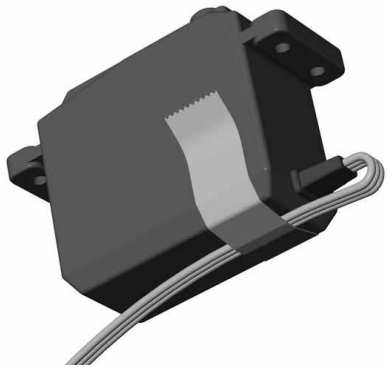

Before installing Aileron Servo, tape the wire as shown.

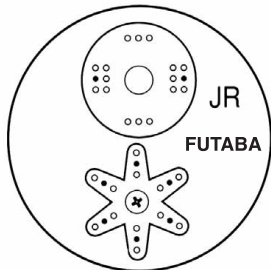

Mount the Steel Linkage Balls at 10.5mm (approx 7/16") from the center of the servo horn.

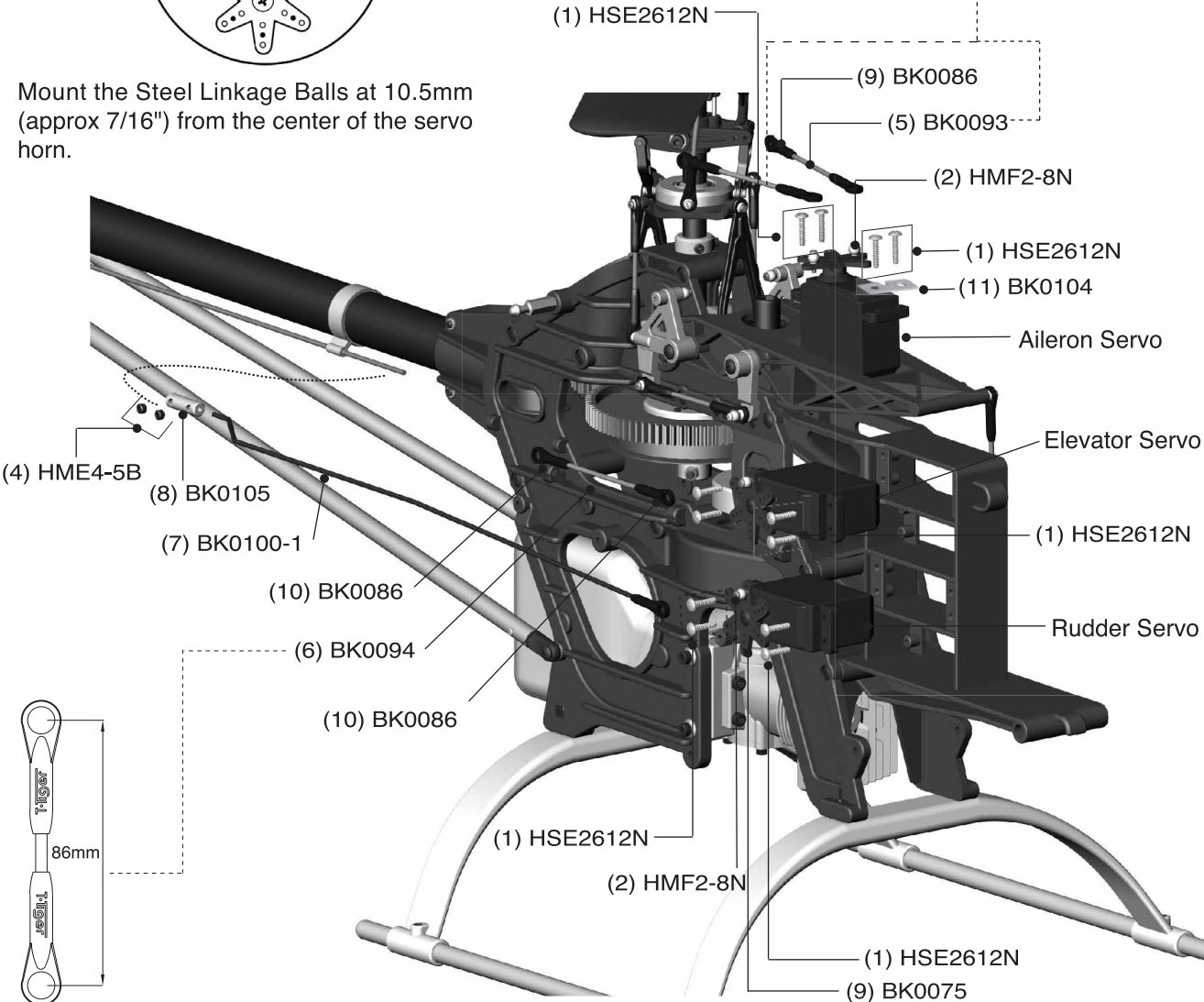
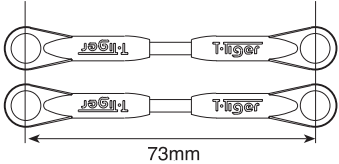

## 17 Servo Installation-Part2

Assembly Tip: Remove all the servo wheels prior to attaching the steel linkage balls. Make sure all linkages are the correct length. See Engine-Throttle Control Linkage on page 17.

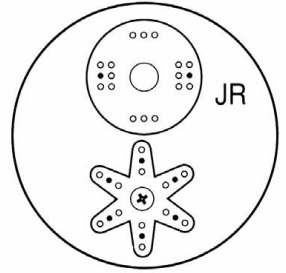

Mount the Steel Link Ball at 10.5mm (approx 7/16") from the center of the servo horn for the throttle arm.

- (1) HSE2612N Self Tapping Screw(M2.6x12).... 8
- (2) HMF2-8N Screw(M2x8)..... 3
- (3) HML2 Hex Nut(M2)..... 3
- (4) BK0075 Linkage Ball..... 3
- (5) BK0094 Linkage Rod ..... 1
- (6) BK0092 Linkage Rod ..... 1
- (7) BK0086 Ball Link..... 4

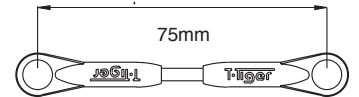
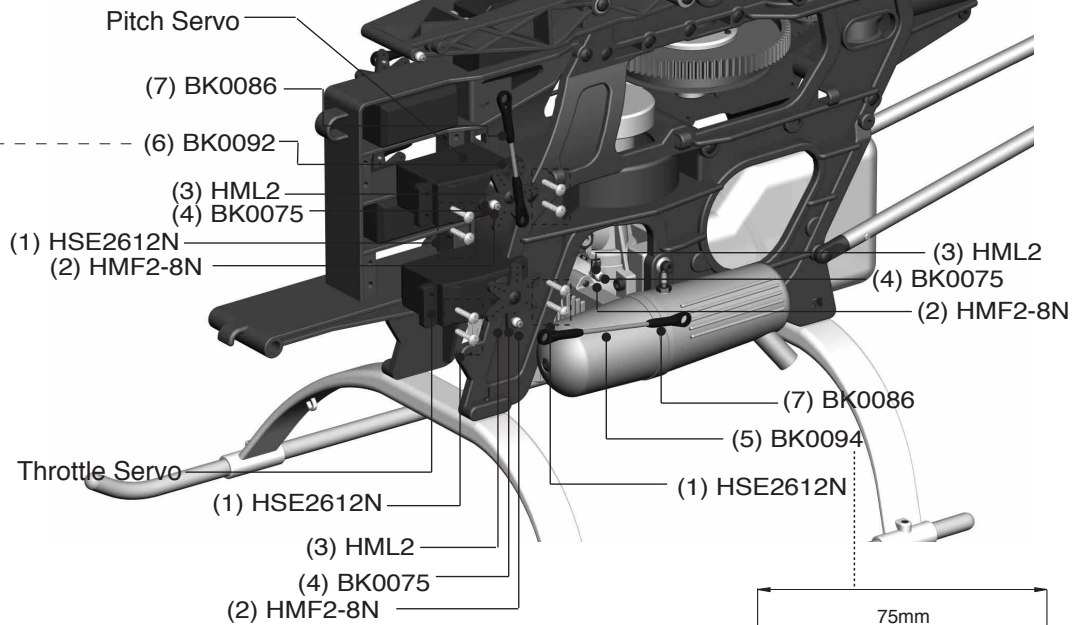
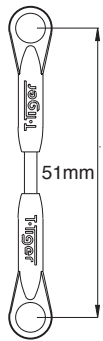

## 18 Receiver/Gyro Installation

Thunder Tiger recognizes that there are many brands of radios and gyros to choose from. You are encouraged to seek the advice of experienced helicopter pilots when making this decision.

- (1) BE1052 Antenna Tube..... 1
- (2) BK0106 Double Side Tape..... 2

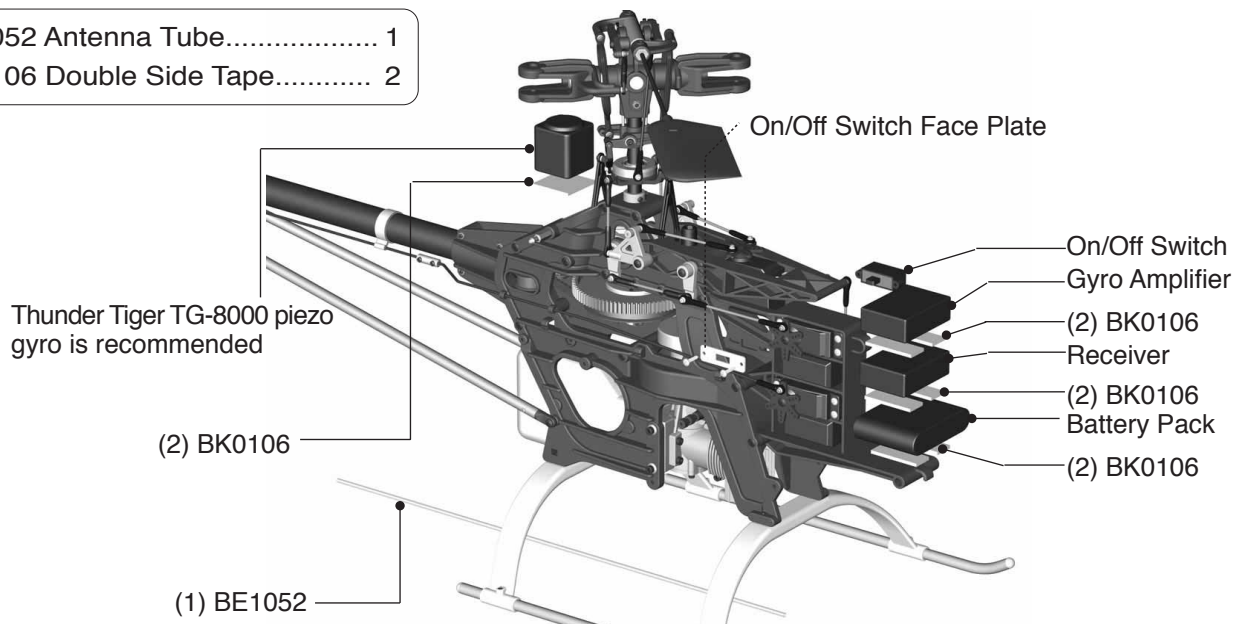



## 19 Body/Canopy Assembly

Cut off the bubble from the body leaving the lip all the way around. Neatness counts, so take your time. Next trim the flange from the canopy leaving a clean edge. You can lightly sand the edges to get it smooth and even. On the lip of the opening in the body, mark six points for drilling holes to secure the canopy: 1-in front, 1-in rear and 2 on each side.

Using double stick tape secure canopy to body. Take a very sharp awl and make pilot holes through the canopy and body lip. Make sure all holes line up. Remove double stick tape and put in the self tapping screws. Install the body clip, decals, and rubber grommets.

- |  |   |
|--|---|
| (1) HMJ2-6B Self Tapping Screw(M2x4)..     | 6 |
| (2) HSE3-12B Self Tapping Screw(M3x12).... | 2 |
| (3) BK0611 Body.....                       | 1 |
| (4) BK0102 Rubber Grommet .....            | 2 |
| (5) BK0098 Body Clip-A.....                | 1 |
| (6) BK0099 Body Clip-B.....                | 1 |
| (7) BK0612 Canopy.....                     | 1 |
| (8) JV0110 Decal.....                      | 1 |

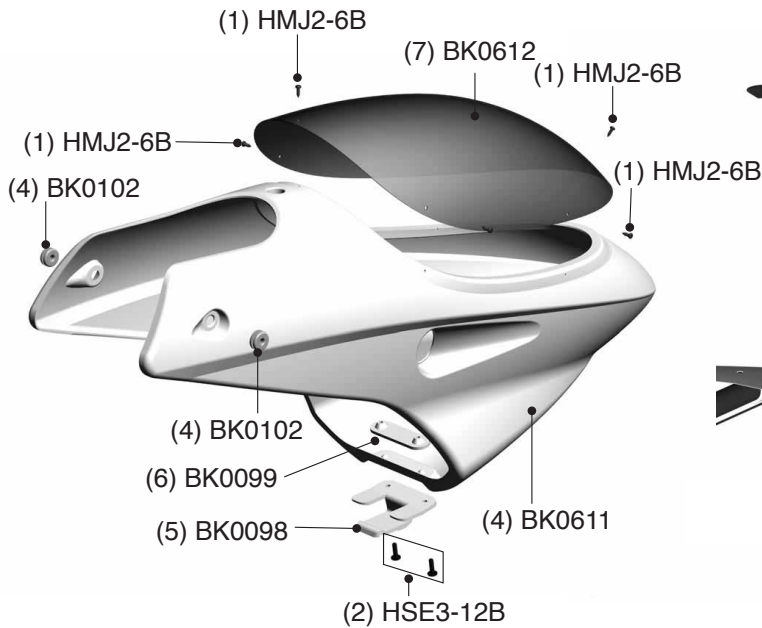

## 20 Main Rotor Assembly

Important-While Thunder Tiger takes great care to manufacture the most balanced blades available, no two rotor blades are exactly the same. It is highly recommended that you purchase a blade balancer from your hobby dealer. Follow the manufacturers instructions for balancing the blades and install on helicopter .

- |  |   |
|--|---|
| (1) BV0176 Main Rotor Blade.....               | 2 |
| (2) HMD2612B Self Tapping Screw (M2.6x12)..... | 2 |
| (3) BK0073 Upper Blade Grip.....               | 2 |
| (4) BK0074 Lower Blade Grip.....               | 2 |
| (5) HMM4Z Lock Nut(M4).....                    | 2 |
| (6) HMC4-27B Socket Screw.....                 | 2 |

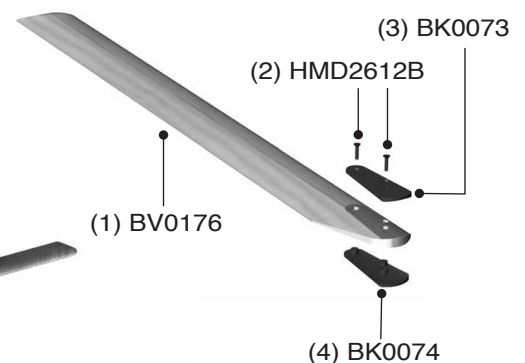
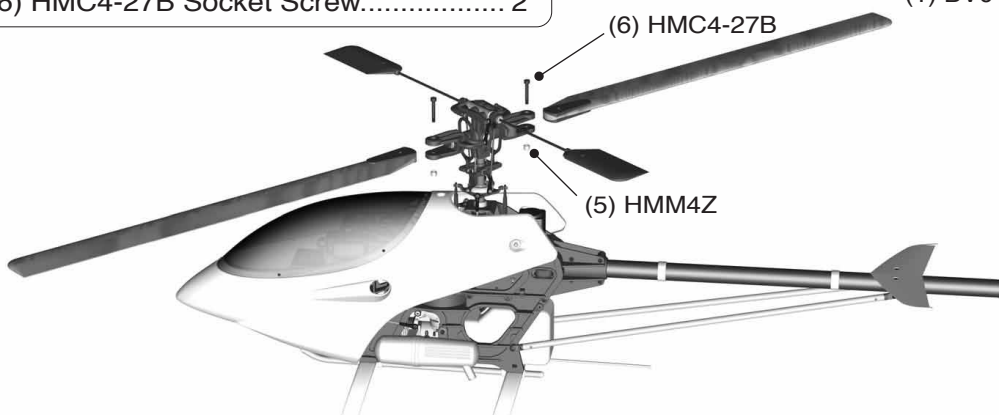



## Engine Throttle Control Linkage

Mount the steel linkage ball to the outer hole on the metal throttle arm. At full throttle stick, the carburetor hole should open completely. At low throttle and with the throttle trim all the way down, the carburetor hole should close completely. Adjust the ATV function in your transmitter to achieve the above requirement. Listen to the servo, it should not make any binding noise. Try keep the throttle ATV between 90% and 110%. If your radio does not have ATV, then adjust the location of the steel link ball on the throttle servo horn to get the correct throttle travel.

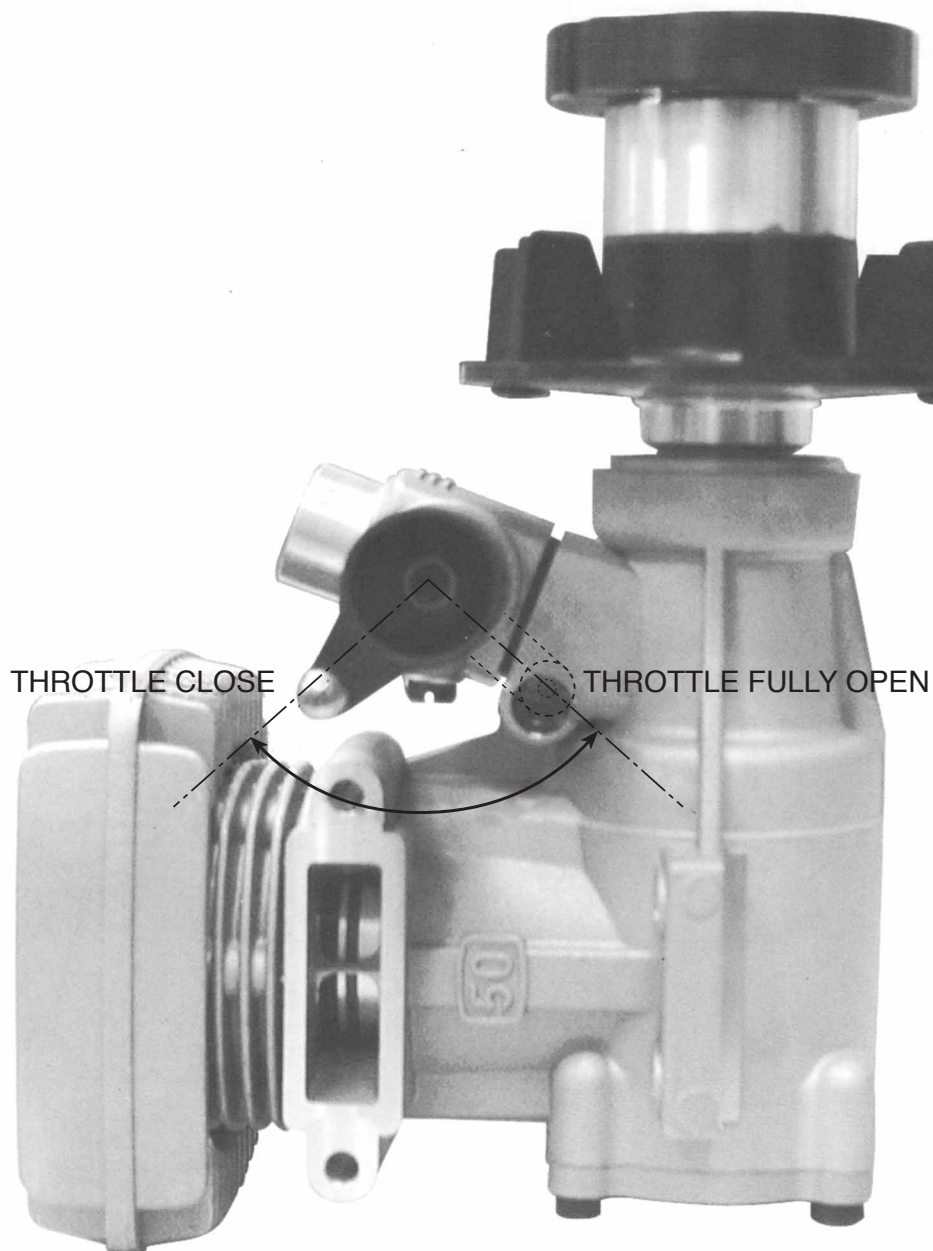

# LINKAGE SET-UP SECTION

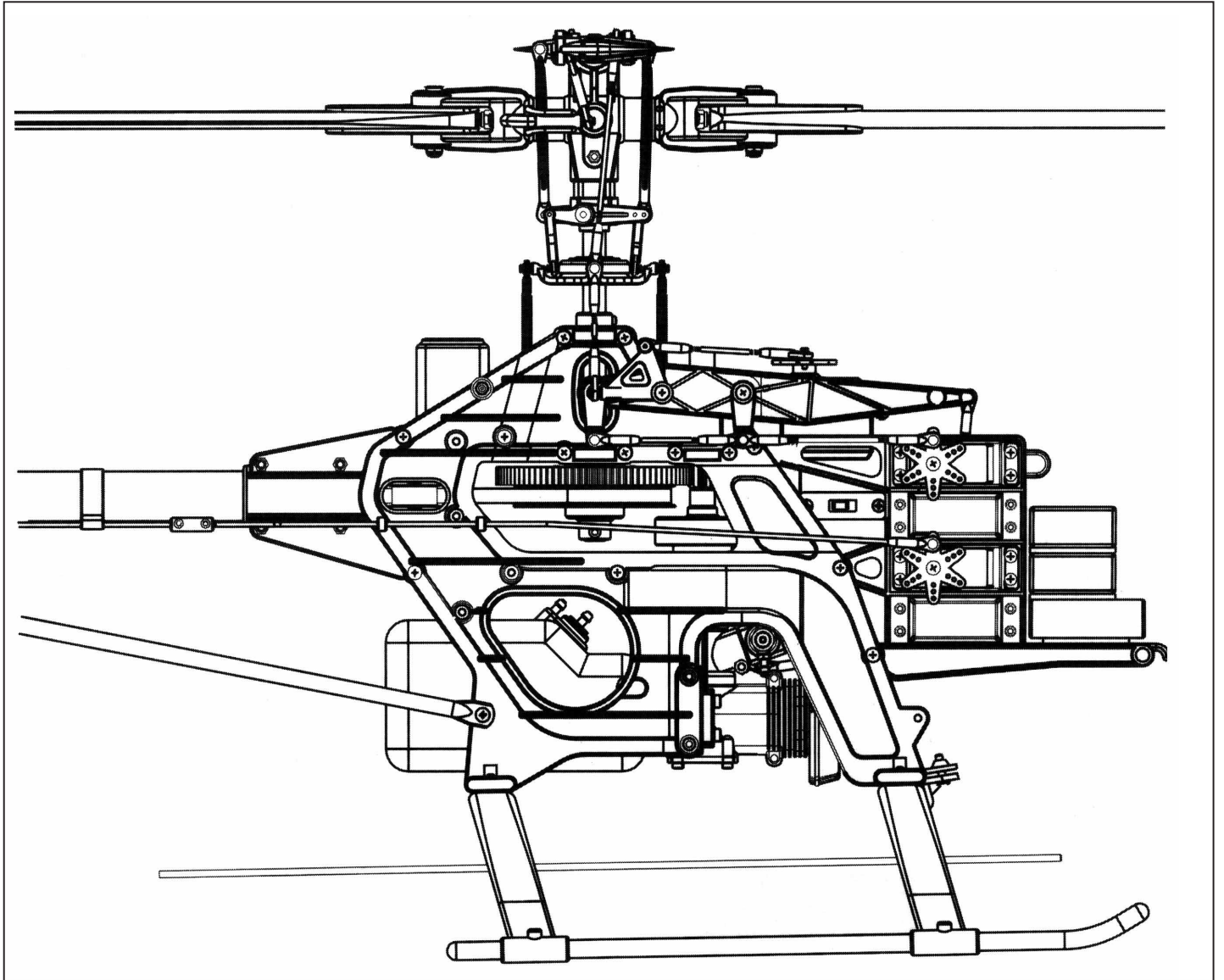

## Setting up Main Rotor Blades Pitch Angle

- On the left side frame, there are three pitch scales molded onto the plastic frame. The three different scales are designed for beginner, intermediate or expert F3C and 3D pilots.
- Use the "pointer" on the collective tray and the plastic molded scales to set up the initial collective control.
- The actual blade angle in degrees can be checked using a pitch gauge (sold separately).

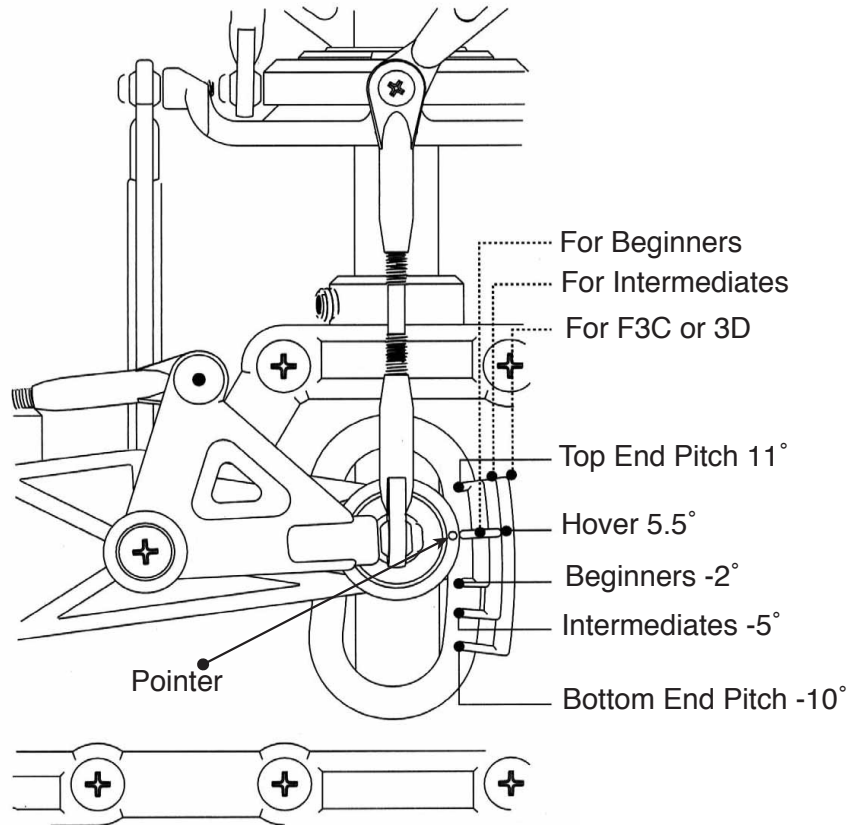

The hovering pitch angle should be at 5.5°. To get the -2° to 11° collective range, mount the steel linkage ball at 13~15mm away from the center of the collective servo horn.

### (Hint for beginners)

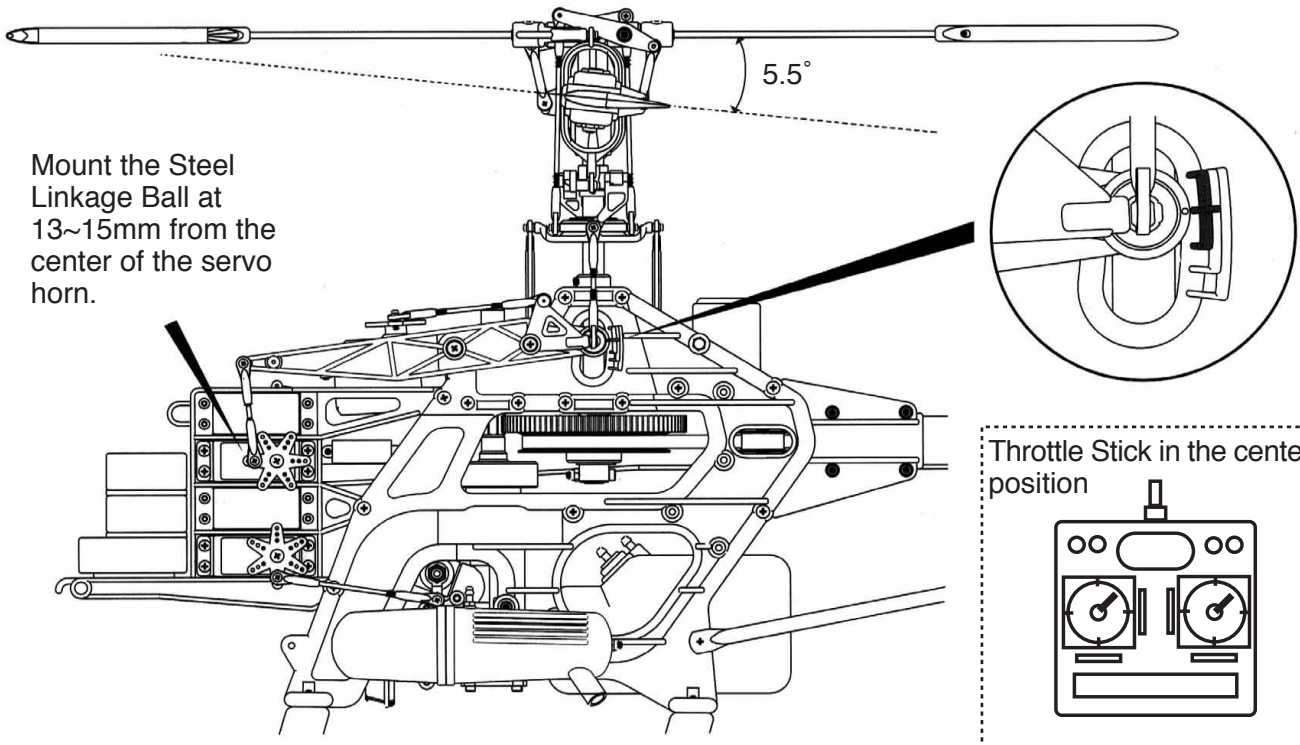

Mount the Steel Linkage Ball at 13~15mm from the center of the servo horn.

Throttle Stick in the center position

5.5° hovering pitch angle is used for beginners, intermediates and experts. The throttle/collective must be in the center position when adjusting the collective pushrod length to make the "point" line up with the 5.5° hover point on the molded scale (see above diagrams).

## ■ High End Blade Pitch Setting

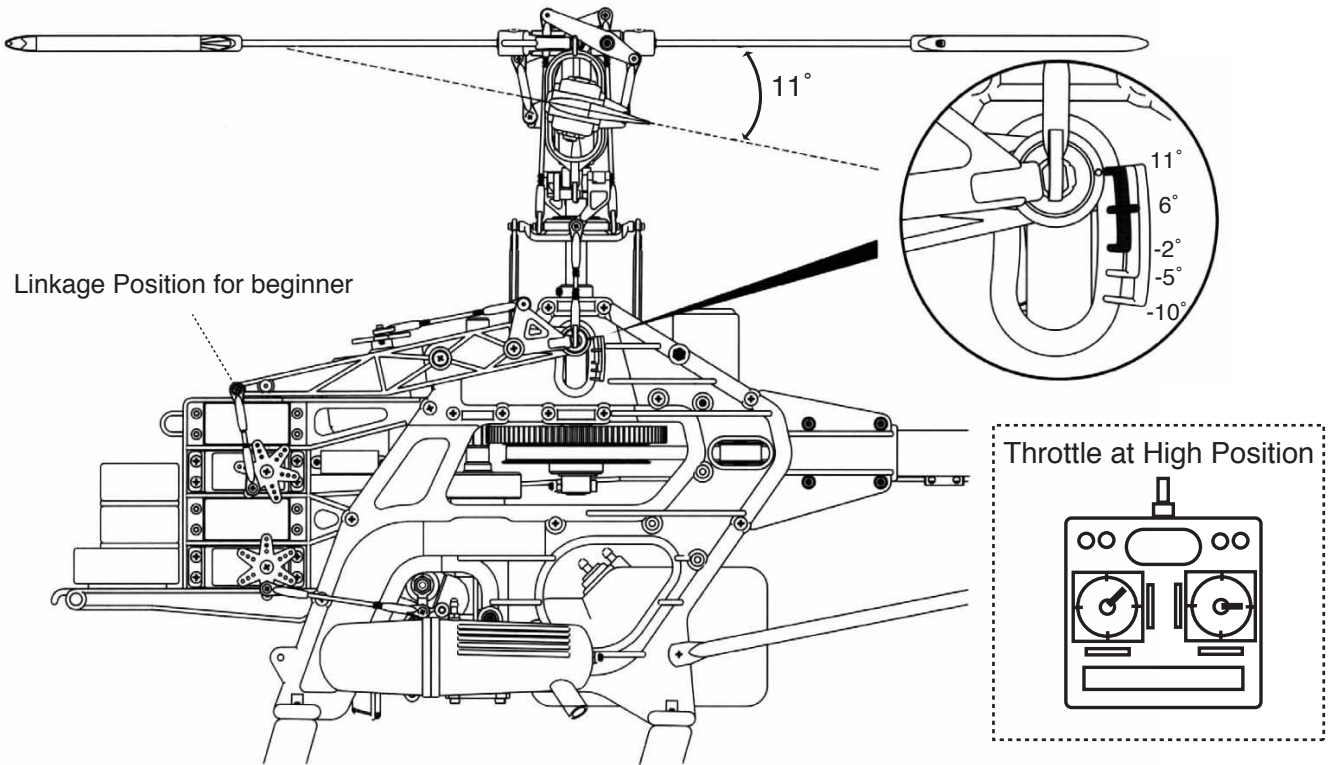

- Move the throttle/collective stick to the full throttle position (see upper right diagram). The molded "pointer" should now line up with the upper limit mark, which should provide about 11° of blade pitch.

## ■ Low End Blade Pitch Setting

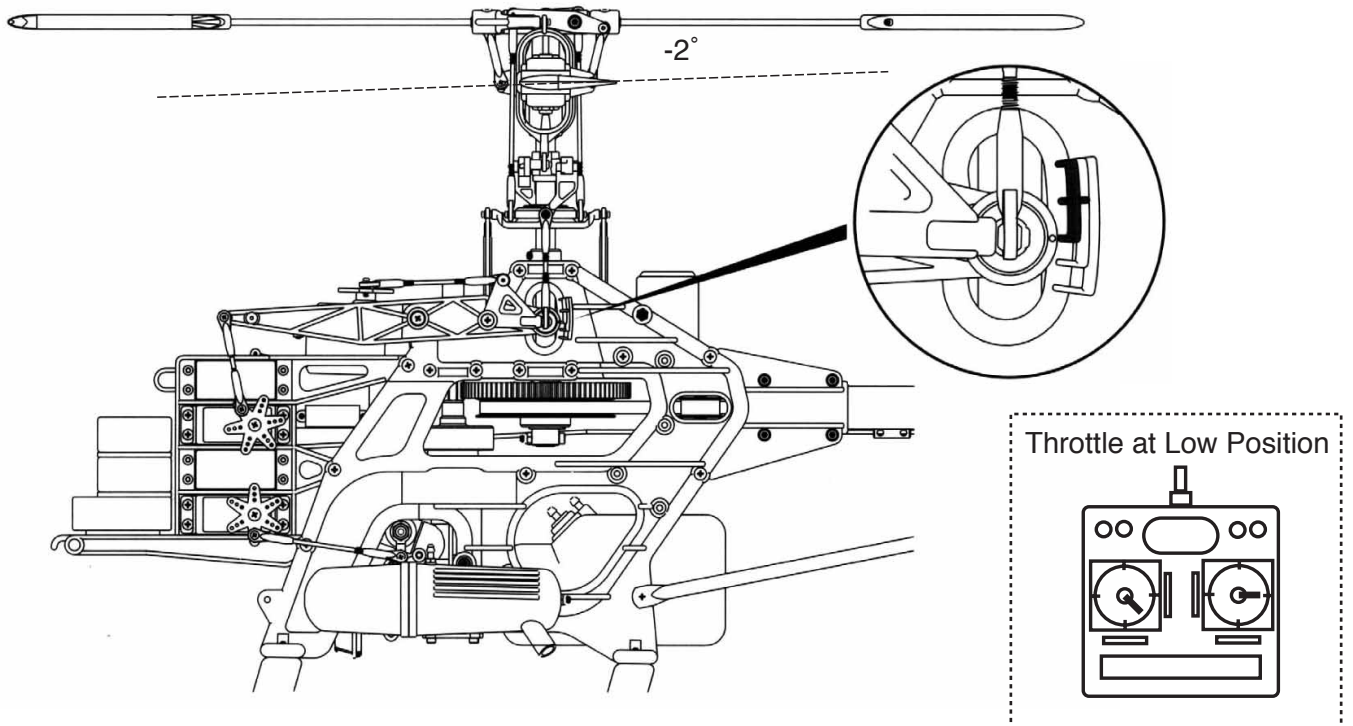

- Move the throttle/collective stick to the low stick position. Use the ATV function of your transmitter to make the "pointer" line up with the -2° mark for beginners (with the -5° mark for intermediates, and -10° mark for experts).



## Collective Travel for F3C and 3D Flying

- To achieve  $+11^\circ$  to  $-10^\circ$  of collective travel range, the steel linkage ball must be moved to the inner location as shown in the figure.
- Use the ATV function of the transmitter to get the necessary servo travel.

### High End Blade Pitch Setting

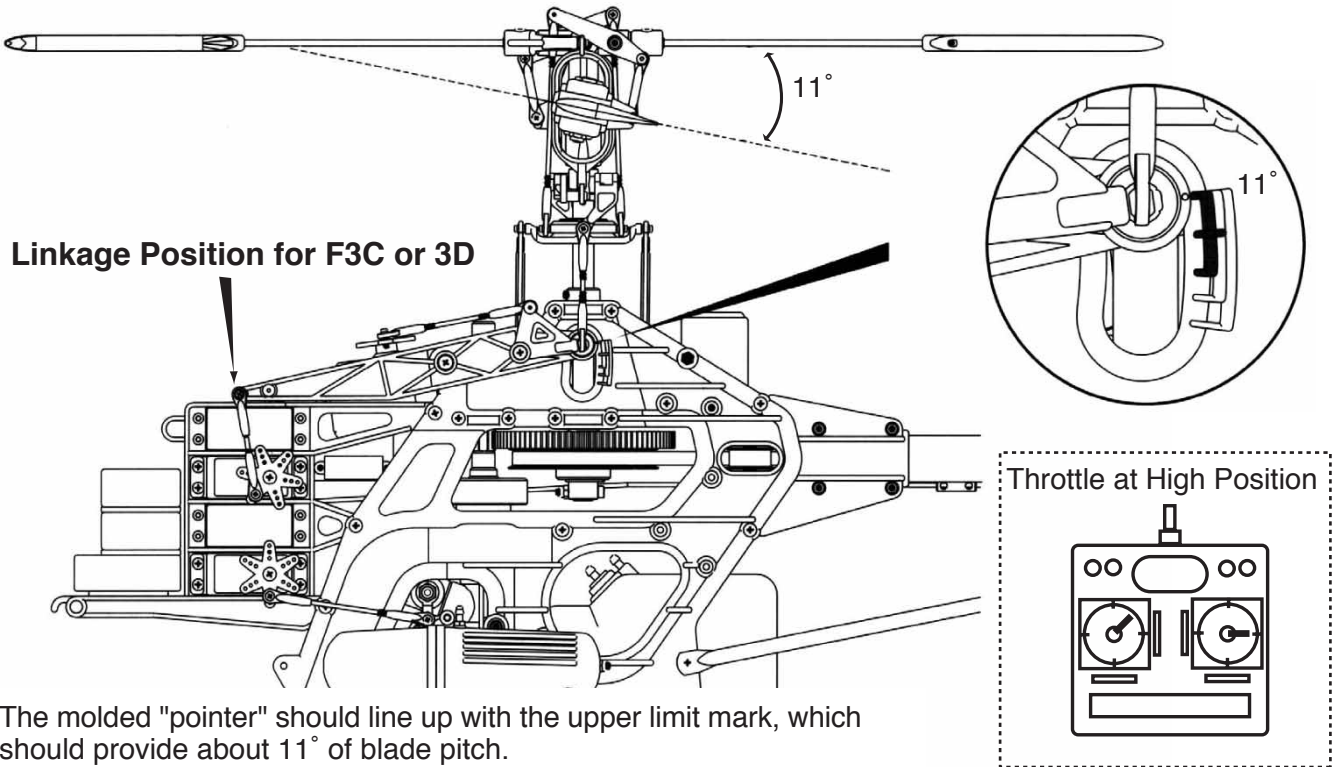

### Low End Blade Pitch Setting

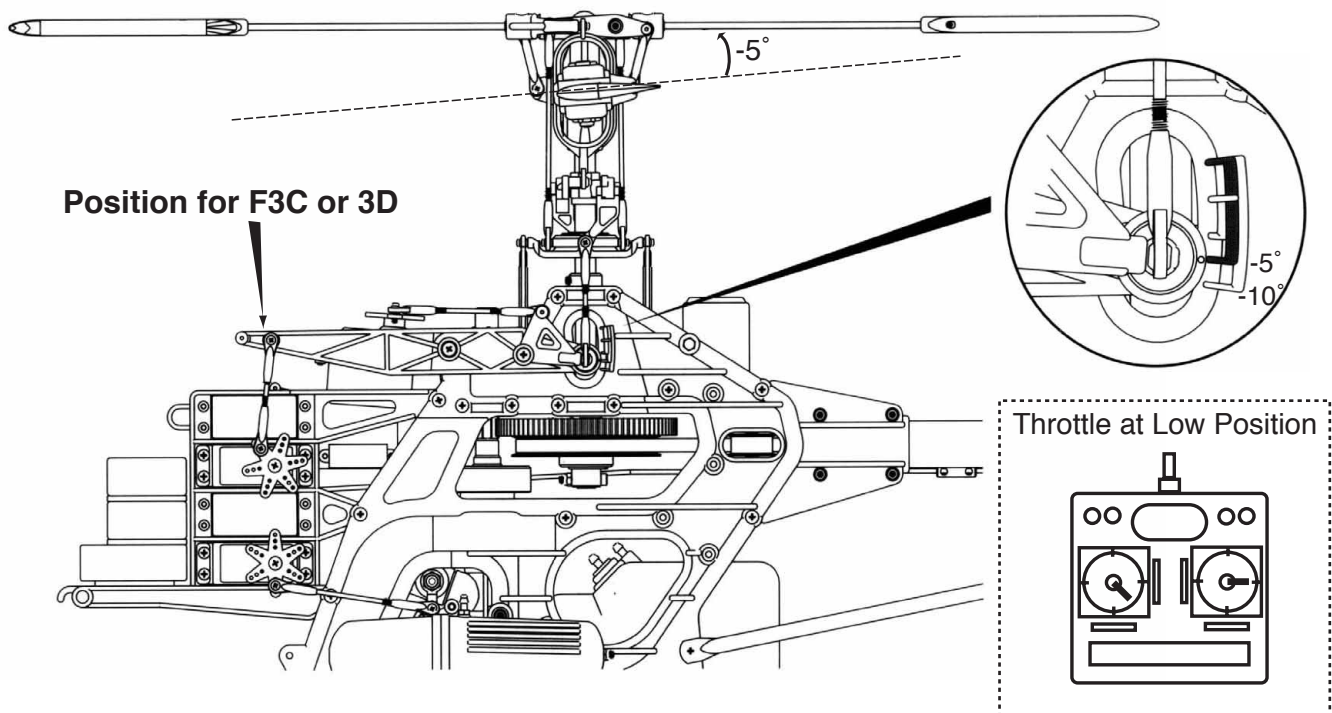

For intermediates set the low end to  $-5^\circ$ . For advanced F3C and 3D flying, set the low end to  $-10^\circ$ .



# CONFIGURING THE RAPTOR FOR 3D

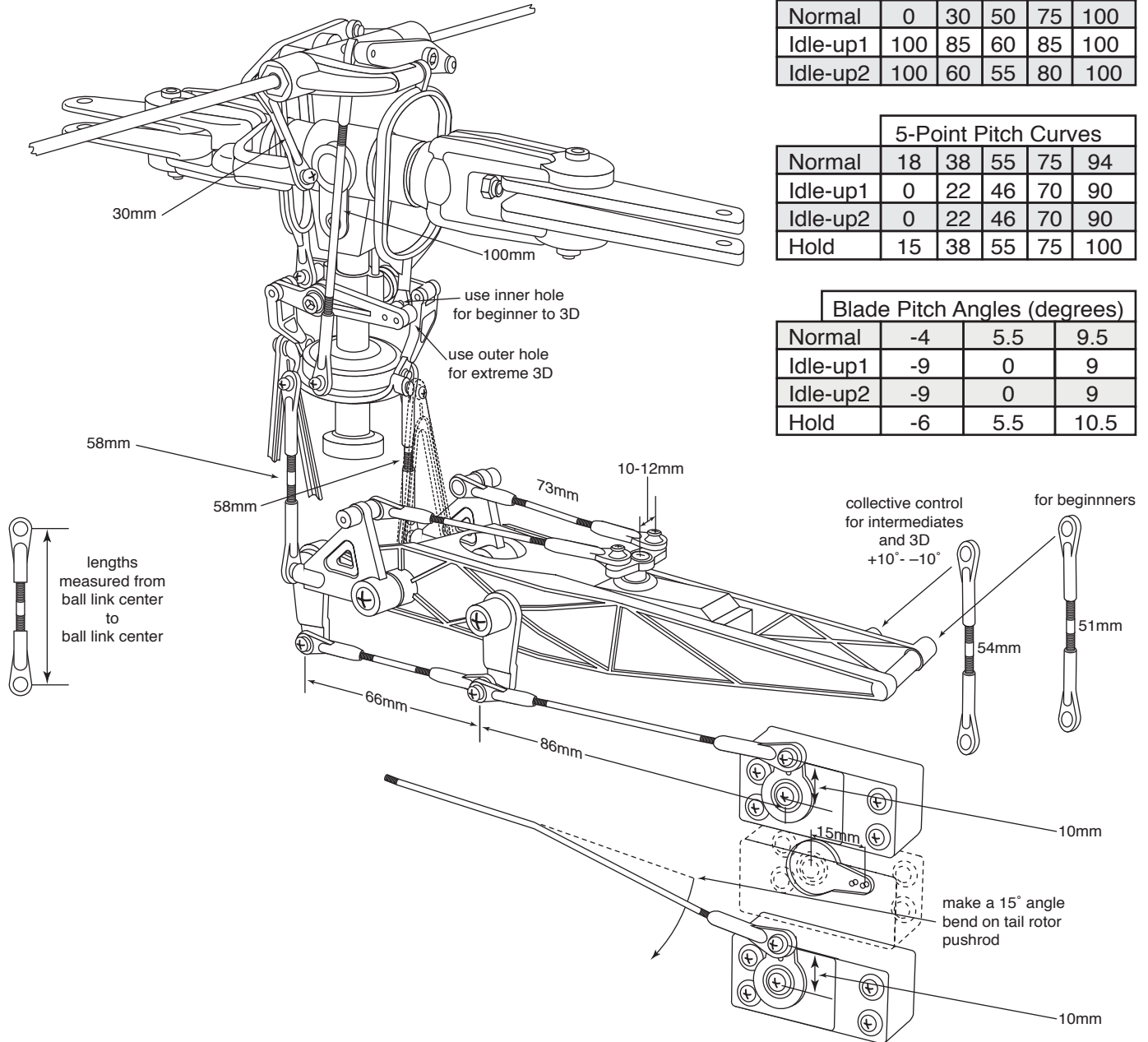

The above pushrod lengths will permit 3D with the Raptor.

Use these lengths as a starting point. Beginners can also use those pushrod lengths, but just connect the collective control to the outside point on the pitch control arm. Pushrod lengths are measured from ball link center to ball link center.

Suggested throttle and collective pitch set up: Idle-up1 is used for continuous 3-D flips and aerobatics. Idle-up2 is used for switchless inverted hover. Use a pitch gauge to check blade angles. It is easier to start setting up idle-up2 blade pitch angles first. Beginners should inhibit idle-up1, idle-up2 and throttle hold. Beginners should only use the Normal mode values. The model should hover at around 1550 rpm in Normal mode, and flies at 1800 in idle-up1. Rotorspeed can be checked using TTR2000 MTF-301 helicopter tachometer.

# Radio and Control Linkage Setup For Raptor 50

The performance of any RC helicopter and how well it flies depends strongly on how well the model has been set up. We will go through step-by-step on how to set up the transmitter and mechanics linkages to make your Raptor 50 fly at its best. Before you start, please set up the length of all the pushrods according to the recommended lengths given in our 3D setup drawing in the instruction manual. The pushrod lengths we have provided are valid for beginners to expert 3-D flying. Then, we recommend using the reset function of your transmitter to reset all settings to factory default values. Check the end point adjustment, or ATV value, on your transmitter to make sure the values are at 100%. Next we recommend to program the numerical values we have provided in the table for the five points in the throttle curves and for the collective pitch curves. Now you can proceed to do the mechanical adjustments. We recommend to leave the transmitter on during the following adjustments.

## 1. Throttle Adjustment.

The throttle arm on the carburetor should always be parallel to the throttle servo arm. When the throttle barrel is half open, the throttle arm should be straight down. Leave it at this position. Turn on the transmitter and leave the throttle in the Normal Throttle Mode. Set the throttle trim to the bottom and set the throttle stick to the middle. Adjust the throttle pushrod to the correct length. Check the throttle servo travel direction to confirm moving the throttle stick to the high position will move the throttle arm to the full open position. Use a medium length servo arm. Pick a hole on the servo arm so that when the throttle stick is moved to the highest or the lowest position, it will fully open or fully close the throttle arm, and without binding. Now is the time to use the End Point Adjustment or ATV feature on the transmitter to fine tune the throttle servo travel to achieve this. Avoid using too large or too small ATV values. The ATV values should stay between 90% to 100%.

## 2. Collective Pitch Setup

Collective control makes a helicopter ascend or descend by changing the main rotor blade angle. Beginners and advanced fliers must attach the collective control pushrod to different locations on the collective control arm. The difference is that advanced fliers desire more collective travel range, usually +10 to -10 degrees of blade change range. Beginners only need -2 to +10 degrees of blade change range. We assume you have programmed in our recommended values from the Table for the throttle and pitch curves.

### Collective Setup for Beginners:

Only the Normal Throttle Model will be used. We recommend using a collective pitch range of -2 to +10 degrees. Move the throttle/collective control stick to the center. Attach the servo arm so the servo arm is in a horizontal position. The servo output shaft has a spline. Try mounting the servo arm with different orientation until one of the arms becomes close to horizontal. Attach the steel ball to the collective servo arm at about 15 mm from the center of the servo arm. Move the throttle stick to the middle position. Tilt the collective control arm/tray assembly so it is approximately in the middle of its allowable mechanics tilting range. Use the molded pitch scale on the left side of the plastic frame. The pointer on the collective arm should point to the mark for the hover position. See our drawings of the molded scale in the other section of this manual. Attach the pushrod. The pushrod length should be 51 mm as recommended in the drawing. Use a pitch gauge to check the blade angle, it should be around 5.5 degrees. This is what you need for hovering. This gives a hovering rpm around 1500.

# Radio and Control Linkage Setup For Raptor 50

Move the throttle stick to the high position to check if it causes binding. Move the throttle stick to the low position to check if it causes binding. The blade should be at 10 degrees at full collective control stick setting, and -2 degrees at bottom stick position. Use the ATV or End Point Adjustment to eliminate binding, or to make the pitch come out at +10 and -2 at the extremes.

## Collective Setup for 3-D:

We recommend using a collective pitch range of approximately -10 to +10 degrees in the Stunt mode, or idle-up mode. Use approximately -6 to +11 degrees in the Throttle Hold Mode. Please see the table of pitch angle values we have provided for 3-D flying. To set up the collective for the 3-D or F3C flying, we recommend starting with Idle-up Mode, or Stunt Mode. Increase the ATV or End Point Adjustment of the collective channel to 130%. Attach the steel ball to the collective servo arm at about 15 mm from the center of the servo arm. The pushrod should be around 54 mm long. Move the throttle stick to the center position and mount the servo arm so the arm is in a horizontal position. Move the throttle stick to the high position to check if it causes binding. Move the throttle stick to the low position to check if it causes binding. The blade should be at 10 degrees at full collective control stick setting, and -10 degrees at bottom stick position. Use the ATV or End Point Adjustment to eliminate binding, or to make the pitch come out at +10 and -10 at the extremes.

After you have done the above and obtained the +10, 0 and -10 degree collective travel range in idle-up, you will automatically get the proper collective settings for the Normal Throttle Mode and Throttle Hold Mode. This is because you have programmed in the numerical values we have provided in the table.

If the throttle was set up according to described earlier, and the numerical values for the five points from the table have been programmed into the transmitter, you will get the proper U-shaped throttle curve for 3-D flying. We have left the values for idle-up 1 and idle-up 2 the same. Individual fliers can refine the two Idle-up settings to suit the need for different 3-D and F3C maneuvers. With Idle-up on, the main rotor speed should be around 1700 to 1800 for good 3-D flying. We recommend using only carbon graphite main rotor blades for aggressive 3-D flying. Please try the Thunder Tiger 600 mm carbon graphite rotor blades, they are designed for extreme 3-D flying with the Raptor 50. Wood main rotor blades are fine for learning how to fly or for practicing simple maneuvers.

## 3. Cyclic Control Setup

Cyclic controls consist of fore/aft cyclic and left/right cyclic. Fore/aft cyclic is often called elevator control. Left/right cyclic is often called aileron control. Elevator and aileron controls are terms used by airplane pilots. Set the cyclic control stick of your transmitter in the middle and set the trims to the center. Put the swashplate in a level position.

**Fore/Aft Cyclic Setup:** Attach the elevator servo arm to the elevator control servo. The servo arm should point straight up. We recommend attaching the steel ball to the elevator servo arm at about 10 mm from the center of the servo. Adjust the pushrod length from the elevator servo to make the swashplate level.

**Left/Right Cyclic Setup:** Attach the aileron servo arm to the aileron control servo. Mount the servo arm so that the servo arm is close to perpendicular to the servo case. We recommend attaching a steel ball to the elevator servo arm at about 10 to 12 mm from the center of the servo. Adjust the pushrod length from the aileron servo to make the swashplate level. The two pushrods from the aileron servo to the aileron bellcrank should be very similar in length.

# Radio and Control Linkage Setup For Raptor 50

## 4. Tail Rotor Control and Gyro Setup

The radio setup for using a heading hold gyro and a non-heading hold gyro will be different. But the mechanical setup will be the same.

**Heading Hold Gyro Setup:** Set the tail rotor mixing or revolution mixing values to zero for every throttle mode in the transmitter. Leave the tail rotor stick in the center and move the tail rotor trim on the transmitter to the center. Attach the servo arm so the arm is straight up. Mount the steel ball 10 to 12 mm from the center of the servo arm. Attach the tail rotor pushrod rod. The pushrod will require a small 15 degree bent to give a smooth run. See the 3-D setup drawing. Adjust the pushrod rod ball links so the tail rotor rotor blade angle is approximately 15 degree. Check the tail rotor control direction: a right tail rotor command should increase the tail rotor blade pitch angle. A left command reduces the angle. Leave the tail rotor control channel ATV at 100%. Use the hand and rotate the gyro to the left. This should cause the servo to provide a right tail rotor command (increases the tail rotor blade pitch angle). Rotating the gyro to the right should cause the servo to provide a left tail rotor command (reduces the tail rotor blade pitch angle). If the gyro is providing the wrong feedback, then the gyro needs to be mounted upside down. Some gyros have a reverse switch on the gyro box. Never use any tail rotor trim when using a heading hold gyro, that causes the gyro to drift.

**Non-Heading Hold Gyro Setup:** Leave the throttle stick and tail rotor control stick in the center and move the tail rotor trim on the transmitter to the center. Attach the servo arm so the arm is straight up. Mount the steel ball 10 to 12 mm from the center of the servo arm. Attach the tail rotor pushrod rod. The pushrod will require a small 15 degree bent to give a smooth run. See the 3-D setup drawing. Adjust the pushrod rod ball links so the tail rotor rotor blade angle is approximately 15 degree. Check the tail rotor control direction: a right tail rotor command should increase the tail rotor blade pitch angle. A left command reduces the angle. Leave the tail rotor control channel ATV at 100%. Use the hand and rotate the gyro to the left. This should cause the servo to provide a right tail rotor command (increases the tail rotor blade pitch angle). Rotating the gyro to the right should cause the servo to provide a left tail rotor command (reduces the tail rotor blade pitch angle). If the gyro is providing the wrong feedback, then the gyro needs to be mounted upside down. Some gyros have a reverse switch on the gyro box. Go to the tail rotor revolution mix function in the transmitter. Put in a numerical value of +25 for the high end revolution mixing and -30 for the low end revolution mixing. Move the throttle stick to the high position and you should see the tail rotor servo move and "increase" the tail rotor blade angle from 15 degrees to about 25 degrees. Move the throttle stick to the low position and you should see the tail rotor servo moves and "decreases" the tail rotor blade angle from 15 degrees to 0 degrees. This is to compensate for the change in torque on the helicopter fuselage when collective pitch is changed. A heading hold gyro does not need tail rotor revolution mixing because it automatically senses heading changes and feed in commands to lock on the helicopter heading. A non-heading hold gyro can only stabilize the rate that the helicopters nose is rotating.

For 3-D flying with a non-heading hold gyro, it will be necessary to put in a V-shaped tail rotor mixing curve. Try +15 for the high end revolution mixing and -15 for the low end revolution mixing.

## Blade Modification

Idea and original art submitted by Randy Wishon,  
Progressive Technologies, inc.

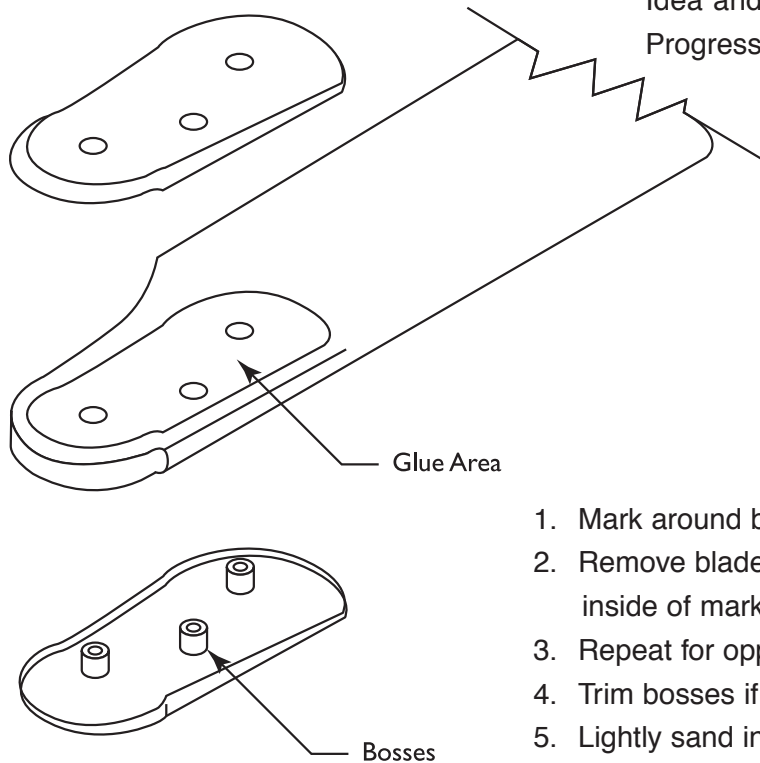

1. Mark around blade grips with a felt-tip marker.
2. Remove blade grips and cut covering lightly .125" inside of mark, being careful not to cut into the blade.
3. Repeat for opposite side.
4. Trim bosses if necessary to allow tight fit to the blades.
5. Lightly sand inside of grips for better adhesion.  
Apply Epoxy to blades in area shown top and bottom.
6. Attach blade grips and tighten screws.
7. Wipe off the excess Epoxy.

### Dear Raptor Customers:

The stock wood blades should be operated with a main rotorspeed of no more than 1700 RPM. For 3-D aerobatics or rotor speeds more than 1700 RPM, the Thunder Tiger 600mm Carbon Fiber Rotor Blade is recommended (P/N TTR 3827). The enclosed drawing illustrates how to remove the plastic blade grips and then carefully slice away some of the covering material, and add the "thin" type CA glue to further strengthen the wood. After installing the plastic blade grips, apply epoxy around the seam of the plastic grip and the wood to seal it off. This adds more strength and prevents oil from seeping through. For beginners, the best rotorspeed is around 1550 RPM. For advanced fliers, a good hovering RPM is around 1550, and a constant 1800RPM in idle-up for 3-D aerobatics. We recommend using the Thunder Tiger TR-2000 optical tachometer to help you check the rotorspeed and to help you set the engine mixture. This tachometer is especially helpful for beginners and we highly recommend it.

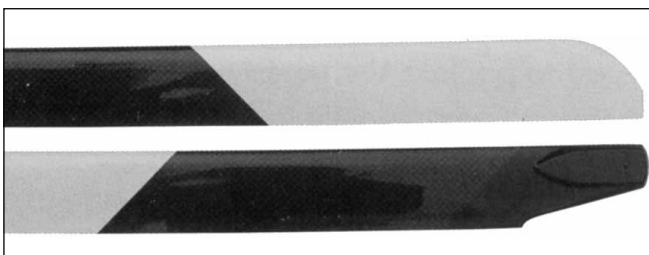

**TTR3827** 600mm Carbon Fiber Rotor Blade



## After Flight Checklist

- (1) Check every screw and bolt to make sure none has loosened due to vibration.
- (2) Check every rotating and movable part to ensure they still move smoothly and normally.
- (3) Clean off the exhaust residue from the muffler, engine, and helicopter.
- (4) Check all movable parts, such as gears, ball links, belt, etc. for unusual wear.

### Trouble Shooting

#### [1] The engine will not start.

\* The engine starting shaft will not turn:

The engine may be flooded with too much fuel. Please remove the glow plug first, then turn the engine with the electric starter until the excess fuel spits out of the glow plug hole.

\* The engine turns when the electric starter is applied, but the engine will not start:

- (1) Is the glow plug working? Remove the glow plug, does the platinum coil glow red when a 1.5 volt battery is applied to the plug? If not, then the glow plug battery may be weak and old.
- (2) Is the carburetor needle properly set? Please refer to the engine instruction manual for proper needle setting.
- (3) Does the throttle control arm move properly and in the correct direction according to your transmitter command?

\* Engine will start, but quits immediately.

- (1) Use the transmitter to increase the carburetor opening slightly. The throttle stick should never exceed the 1/3 position when starting the engine.
- (2) Try a new or different type of glow plug. There are different types of glow plugs on the market for different types of fuel and operating conditions. Seek the advice of experienced fliers and also experiment with different types of glow plugs until you find one that suits your operating condition best.

\* Engine runs, but the helicopter will not lift off.

- (1) Check the main rotor blade pitch angle, it should be set at 5.5 to 6 degrees when the transmitter throttle/collective stick is at the center position.
- (2) Does the engine throttle arm move properly? The carburetor opening should be fully open when the transmitter throttle/collective stick is moved up. The carburetor opening should be completely closed when the transmitter throttle/collective stick is moved down and the throttle trim is also moved down.
- (3) The carburetor needle is not set properly. Close the needle (turn it clockwise) all the way, then open the needle (turn it counter clockwise) 1 and 1/2 turns and try again. If the model still will not lift, then the engine may be running too rich. If the symptom is the engine exhaust has a lot of smoke and the engine coughs and wants to quit when the transmitter throttle/collective stick is moved up, then close the needle 1/8 turn at a time, until the model will lift off. Do not turn the needle too far inward, that will make the engine run too lean and over-heat and damage the engine.

#### [2] Helicopter problems.

\* The helicopter shakes.

- (1) Is the blade spindle bent?
- (2) Is the flybar bent?
- (3) Is the main rotor shaft bent?
- (4) Are the two control paddles mounted at the same distance from the rotor shaft, are the paddles parallel to each other, and in the proper direction?
- (5) Is the tail rotor shaft bent? The tail rotor blades mounted properly or damaged?
- (6) Are the main rotor blades damaged or mounted in the proper orientation? The blades may require additional balancing. The blade balance can be checked by removing both blades and then use one of the 4 mm blade bolt and nut to hold the two blades together like a teeter totter. Then, hold the blade bold with your thumb and index finger. The two blades should teeter and remain in a level position. If not, then add some tape to the lighter blade near the blade tip until the two blades teeter in a level position. Hobby shops also sell blade balancers that are designed solely for balancing model helicopter blades.

# PARTS LIST SECTION

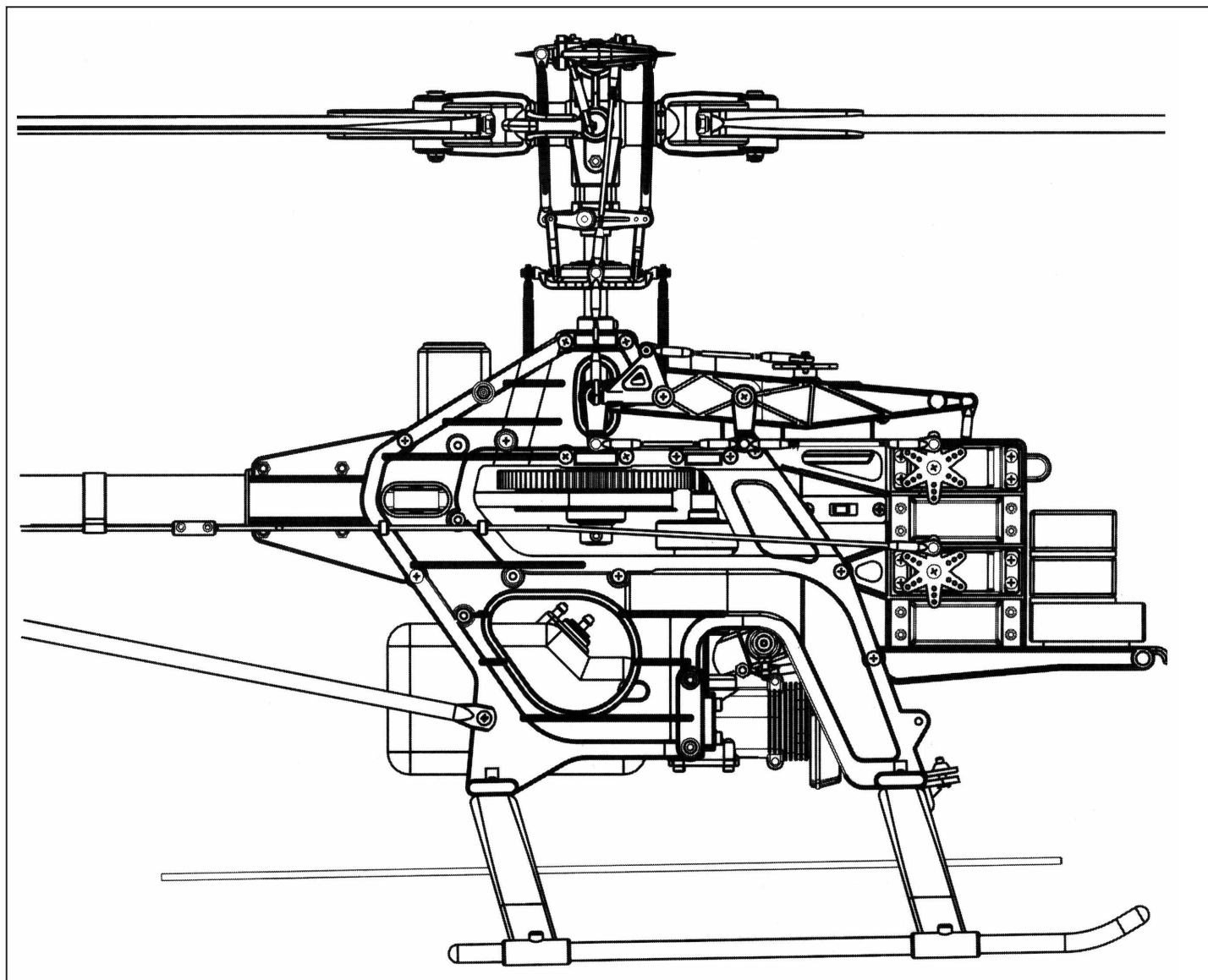

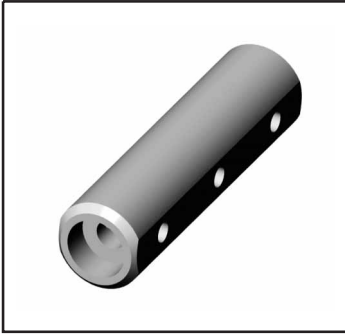

AK0004 Flybar Seesaw

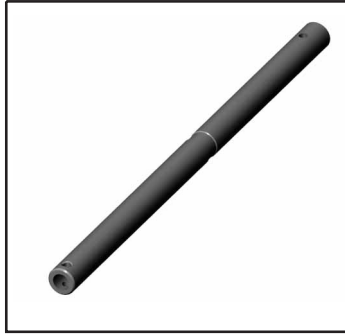

AK0029 Main Shaft

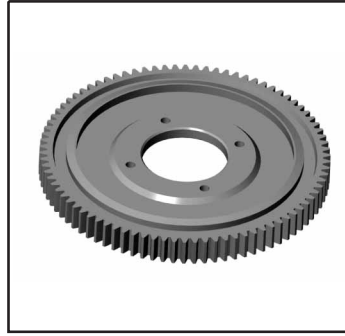

AK0148 85T Main Spur Gear

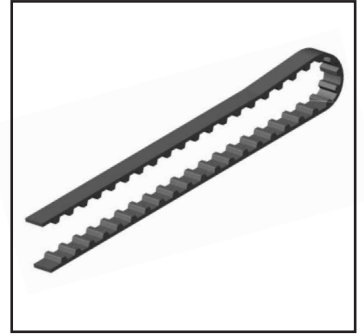

AK0089 Tail Drive Belt

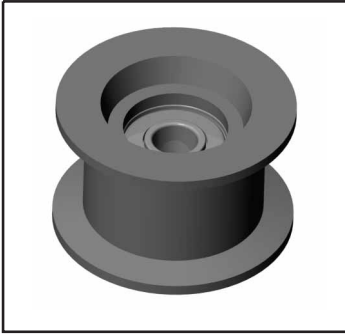

AV0052 Tail Idel Pulley Assy

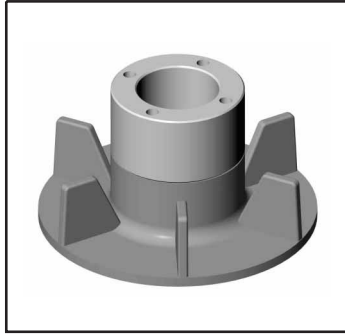

AV0143 Cooling Fan Assy.

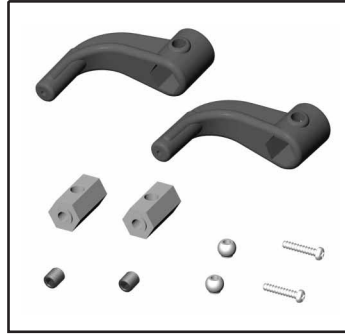

PV0002 Flybar Control Arm



PV0004 Mixing Lever



PV0005 Flybar Control Rod

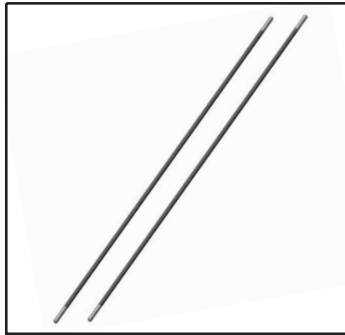

PV0008 Flybar Rod

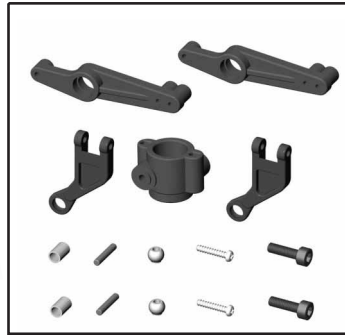

PV0011 Wash Out Set

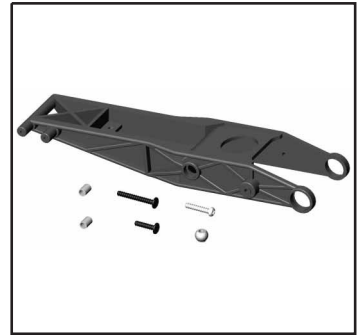

PV0012 Pitch Control Arm



PV0013 Elevator Arm

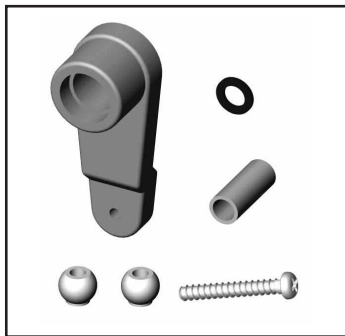

PV0014 Elevator Lever

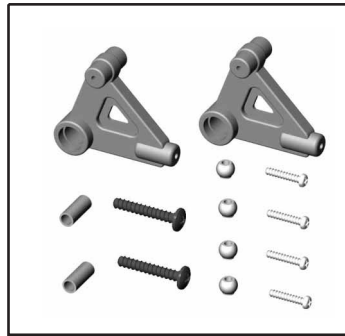

PV0015 Aileron Lever

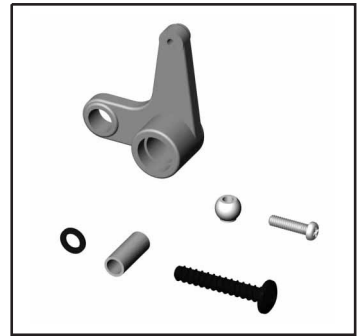

PV0016 Tail Pitch Control Lever



PV0017 Tail Pitch Slider

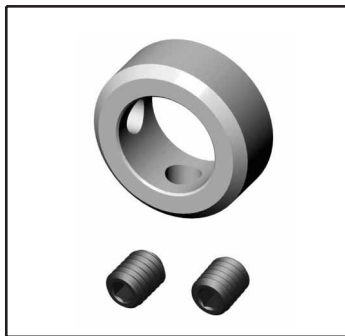

PV0018 Main Shaft Lock Ring

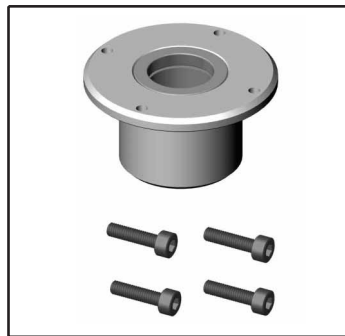

PV0019 One Way Clutch



PV0020 One Way Clutch Shaft

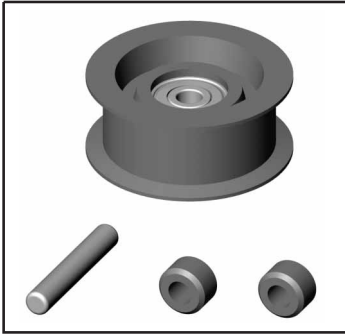

PV0021 Guide Pulley Assy

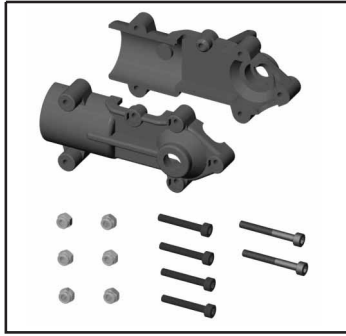

PV0027 Tail Case

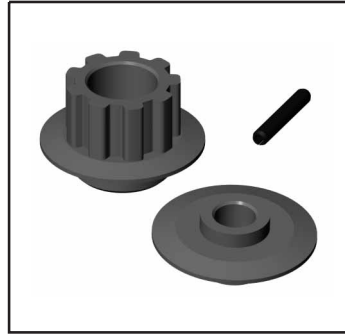

PV0029 Tail Pulley Set

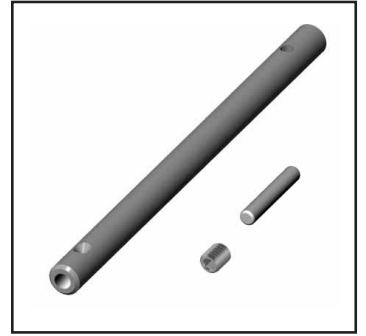

PV0030 Tail Rotor Shaft

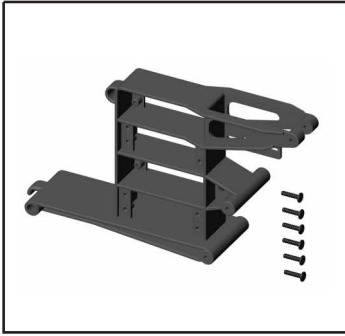

PV0033 Servo Frame

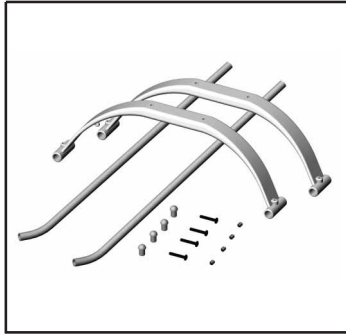

PV0035 Landing Skid set

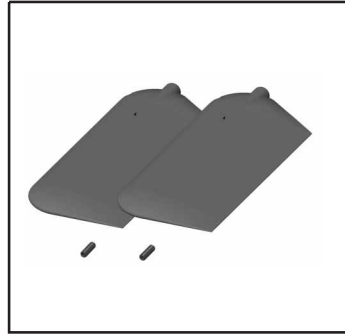

PV0036 Flybar Paddle

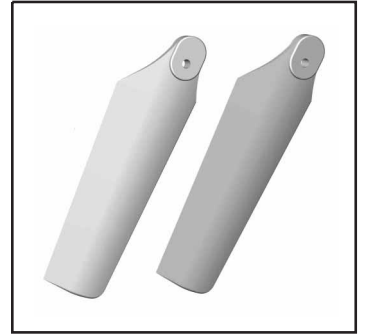

PV0037 Tail Rotor Blade

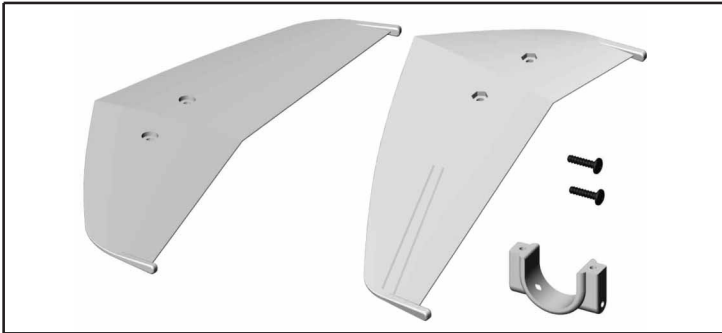

PV0038 Tail Fin



PV0040 Double Link



PV0041 Ball Link

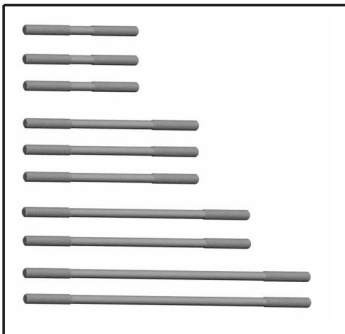

PV0044 Linkage Rod

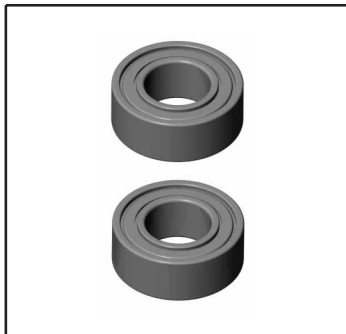

PV0048 Pitch Frame/Rotor Hub Seesaw Brg.

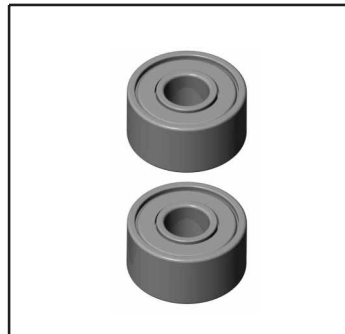

PV0049 Seesaw Brg.

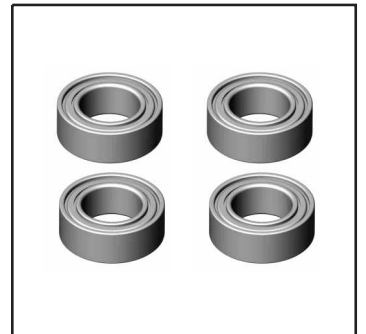

PV0051 Lever Brg.



PV0052 Tail Slider Brg.



PV0053 Rotor Bolt

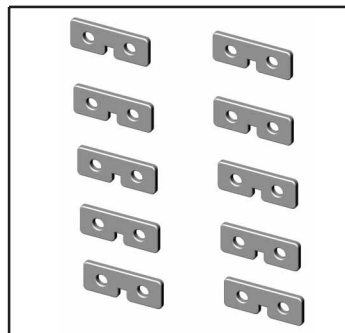

PV0054 Servo Mounting Plate



PV0056 Frame Spacer(L)



PV0057 Frame Spacer(S)

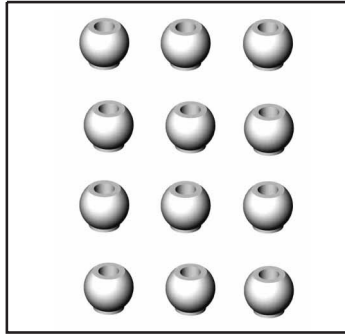

PV0058 Linkage Ball

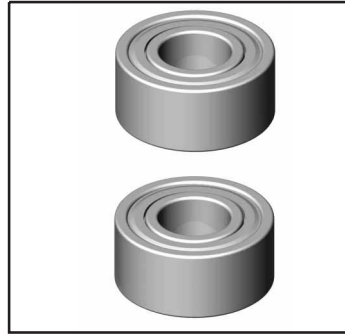

PV0059 Tail Shaft Brg.

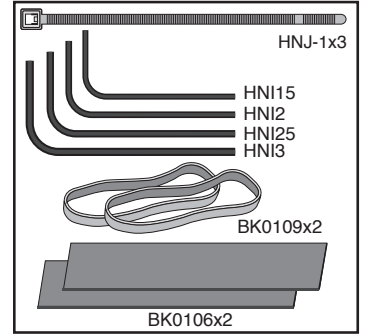

PV0060 Installation Set

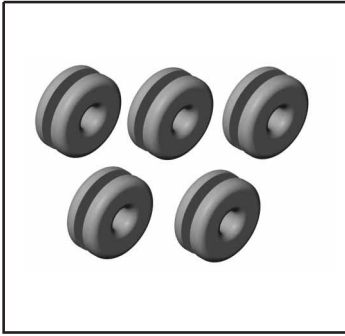

PV0062 Body Mount Rubber Grommets



PV0092 Swashplate

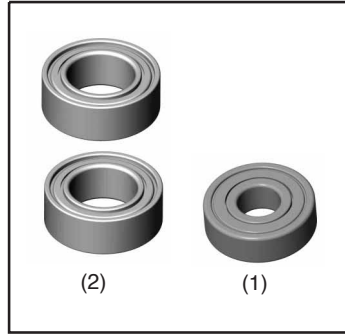

PV0093 Main Shaft Brg



PV0107 Engine Mount (.50)



PV0109 High Performance Muffler (.46~.50)

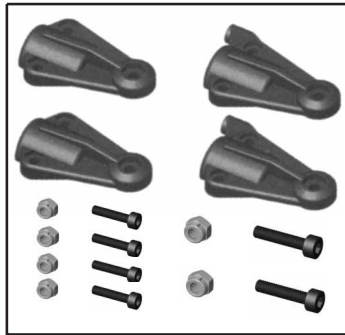

PV0148 Tail Rotor Grip

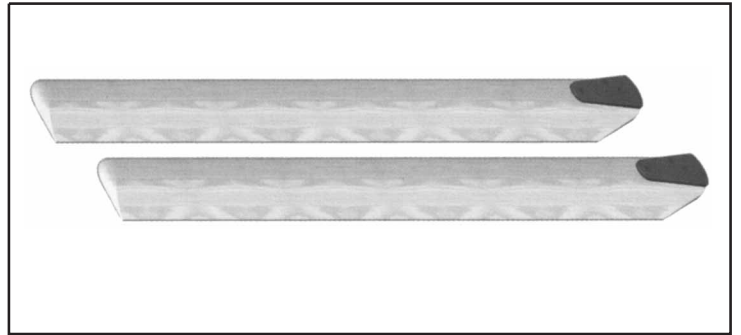

PV0118 Main Rotor Blades



PV0151 Tail Rotor Hub

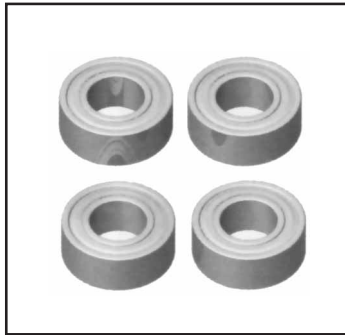

PV0200 Tail Rotor Brg.

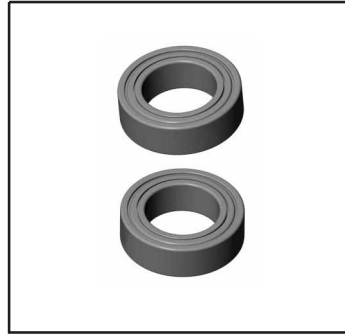

PV0203 Starter Shaft Brg.



PV0267 Loctite #242



PV0268 Loctite #262



PV0270 Grease (For Bearing)

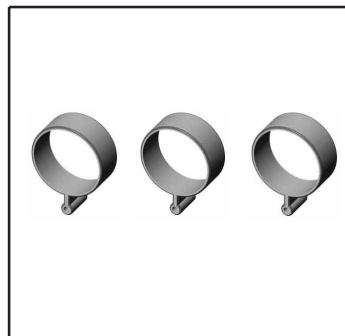

PV0279 Tail Rod Guide



PV0311 Header Tank



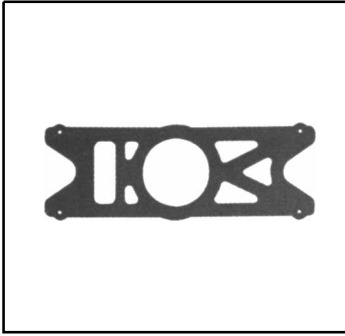

PV0326 Carbon Graphite Base Plate

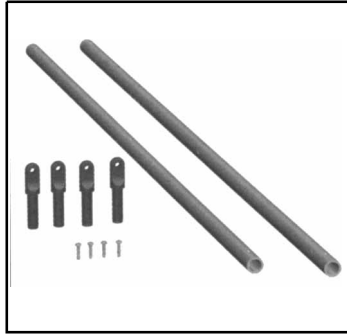

PV0329 Tail Support

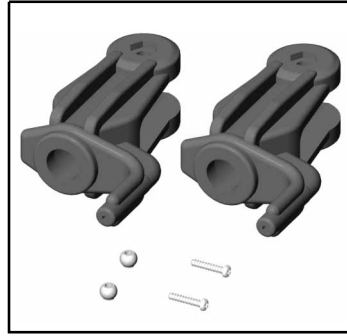

PV0353 Main Rotor Grip

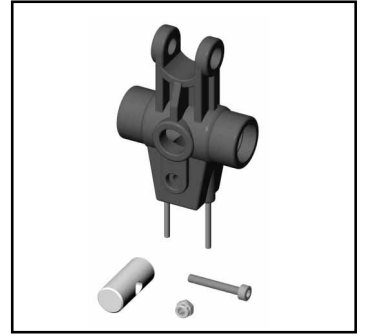

PV0354 Main Rotor Hub

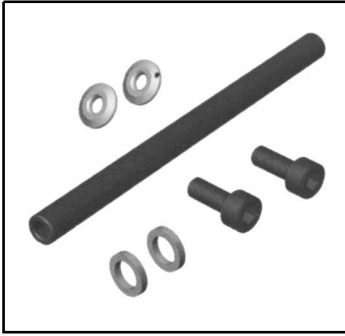

PV0355 Spindle

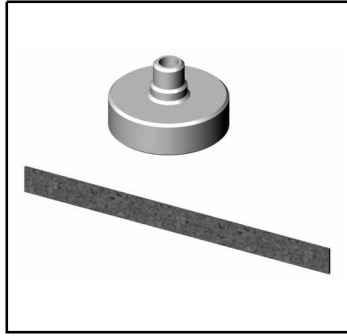

PV0358 Clutch Bell

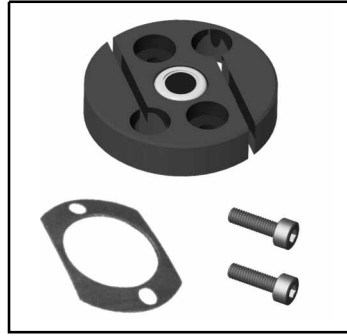

PV0359 Clutch

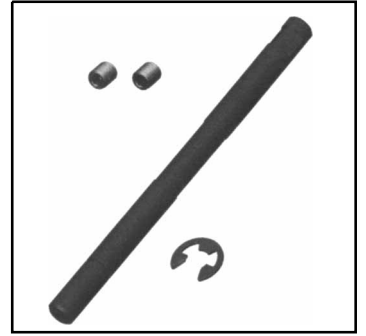

PV0360 Starter Shaft

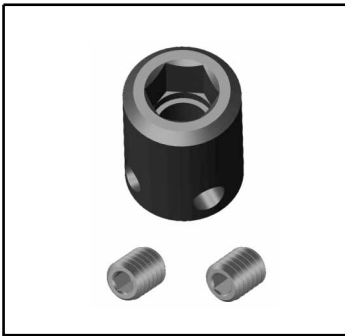

PV0361 Starter Coupling

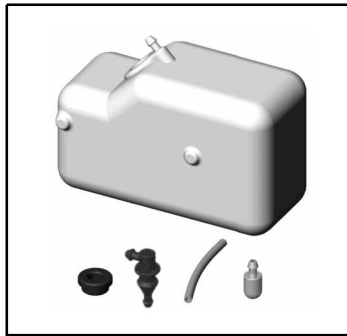

PV0363 Fuel Tank

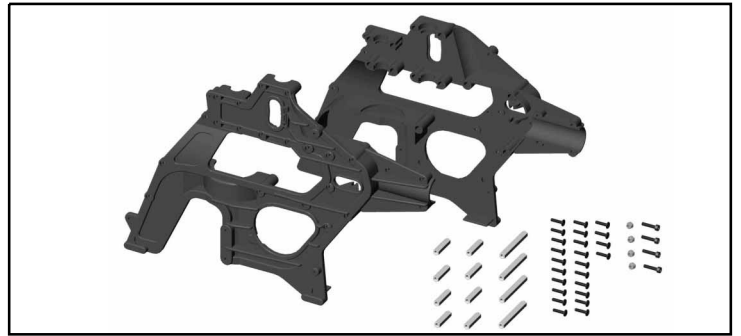

PV0362 Main Frame Set

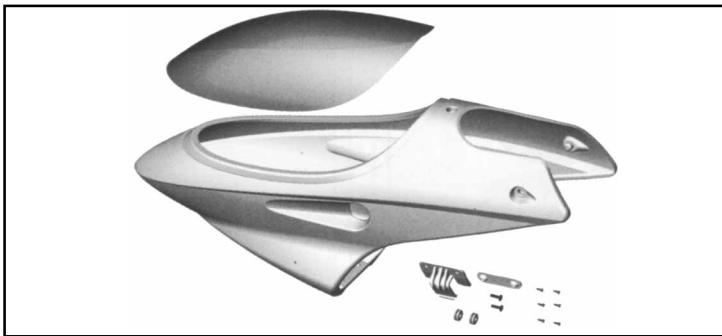

PV0364 Body

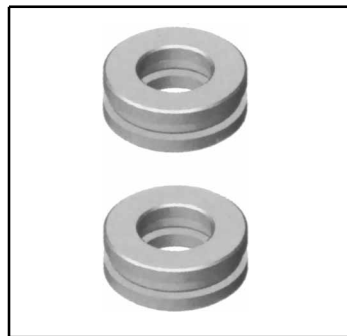

PV0365 Thrust Brg.

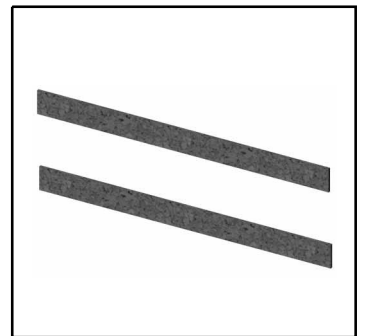

PV0368 Clutch Liner

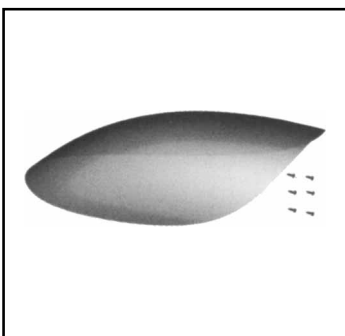

PV0369 Canopy Only

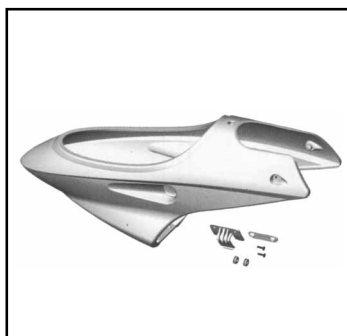

PV0370 Body Only

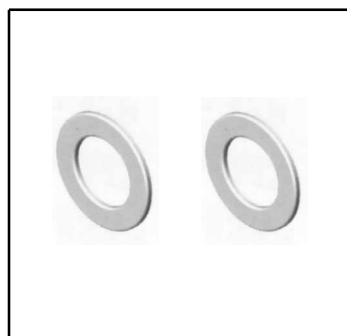

PV0372 Thrust Collar

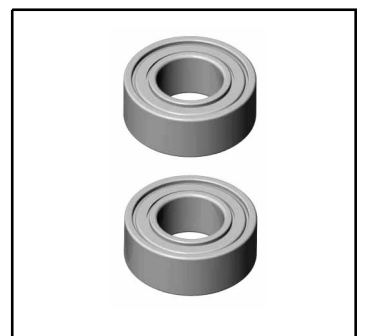

PV0373 Clutch Bell Brg.

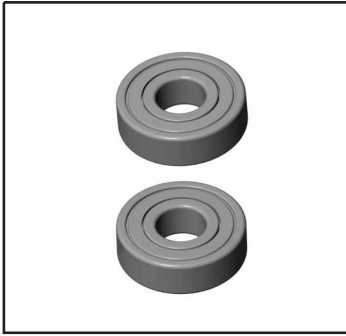

PV0374 Feathering Brg.

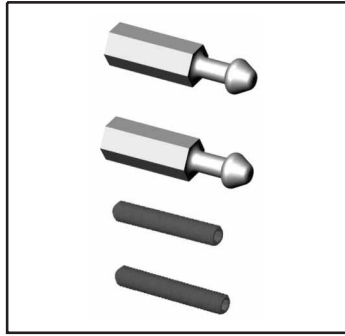

PV0375 Body Retaining Set

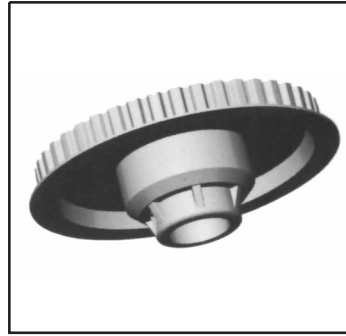

PV0379 Auto Rotation Pulley



PV0380 Pinion Gear 10T



PV0381 70 Durometer Flap Damper

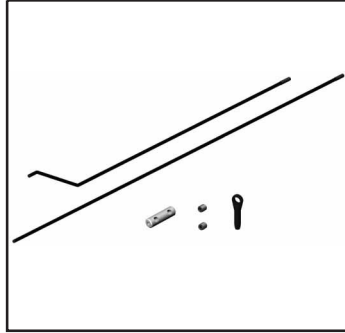

PV0392 Tail Control Rod

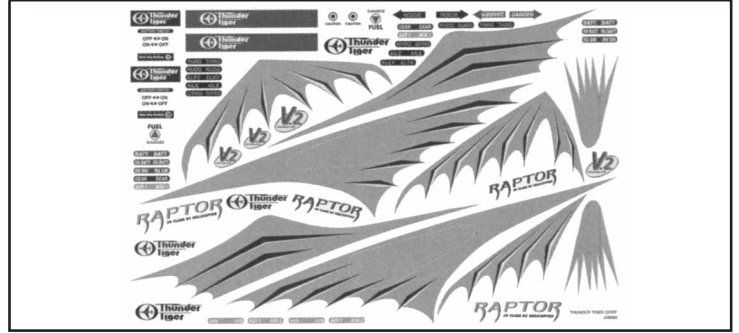

PV0389 Decal

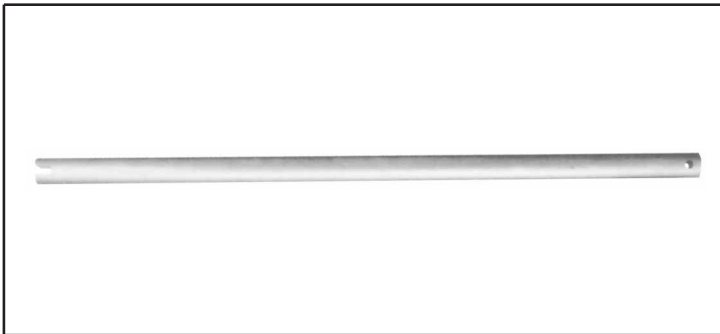

PV0393 R50 Tail Boom

	HMF2-6N M2X6 HMF2-8N M2X8
	HMJ2-10N M2X10 HMJ2-14N M2X14 HMJ2-6B M2X6 HMJ3-22B M3X22
	HSE2-10B M2X10 HSE2612N M2.6X12 HSE3-12B M3X12 HSE3-18B M3X18
	HSE3-5B M3X5

PV0088 Screw Bag (6pcs each)

	HMC3-10B M3X10 HMC3-12B M3X12 HMC3-14B M3X14 HMC3-20B M3X20 HMC3-25B M3X0.5L25 HMC3-32B M3X0.5XL32 HMC3-8B M3X8 BK0616 M3X20
	HME3-10B M3X10 HME3-18B M3X18 HME3-5B M4X5

PV0089 Screw Bag (6pcs each)

# HELICOPTER ACCESSORIES



NO. 3800 BLADE SUPPORT

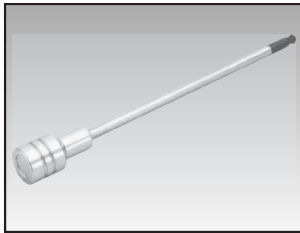

NO. 3801 6MM STARTER EXTENSION

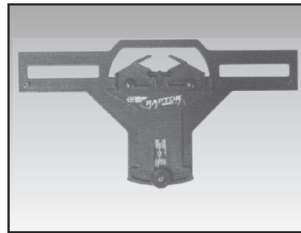

NO. 3802 PRECISION PITCH GAUGE

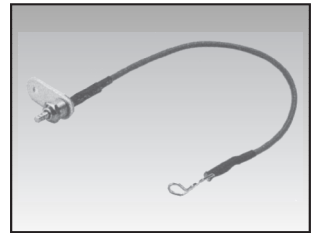

NO. 3803 REMOTE GLOW ADAPTER



NO. 2000 TERA ON-BOARD DIGITAL TACHOMETER



NO. 8000 TG-8000 GYRO

# OPTIONAL PARTS

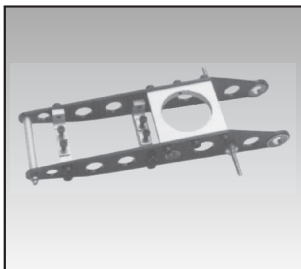

PV0068 ALUM COLL SERVO TRAY

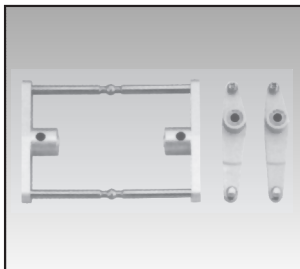

PV0095 STABILIZER CONTROL ARM SET

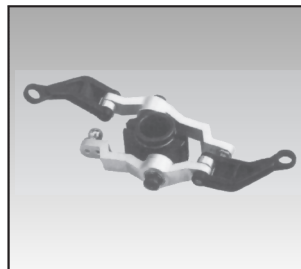

PV0096 WASHOUT ASSEMBLY

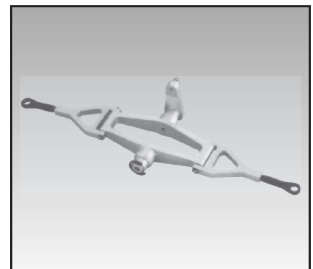

PV0097 ELEVATOR LEVER SET

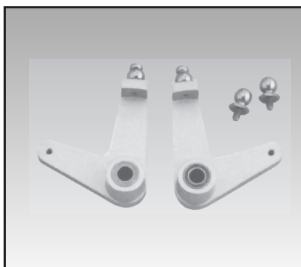

PV0098 AILERON L-TYPE LEVER



PV0100 CARBON FIBER TAIL SET

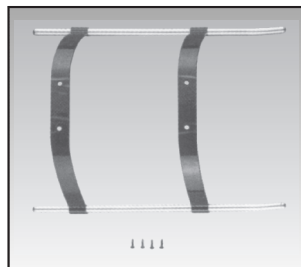

PV0101 CARBON FIBER SKIDS

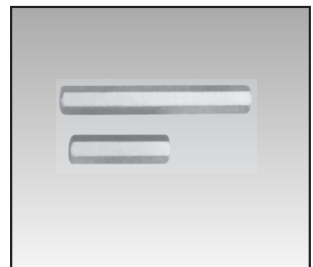

PV0104 ALUMINIUM FRAME POST



PV0106 COOLING FAN (.50)

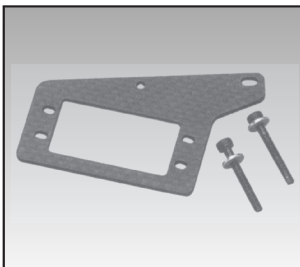

PV0321 REAR MOUNTED TAIL SERVO TRAY

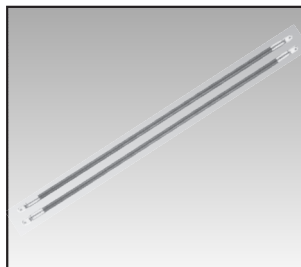

PV329 CARBON TAIL BOOM BRACE

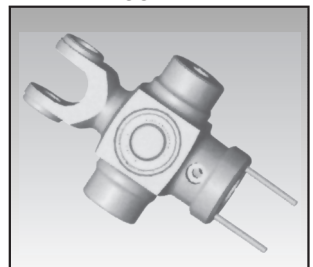

PV0338 METAL MAIN ROTOR HUB



PV0339 METAL MAIN ROTOR GRIP

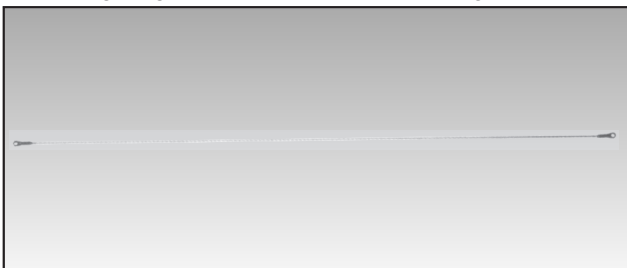

PV346 R50 REAR SERVO ROD



PV0341 METAL TAIL PITCH SLIDER

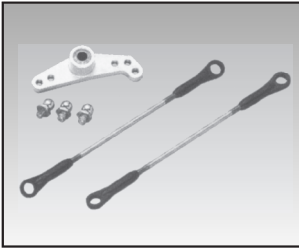

**PV0349** PUSH/PULL ELEVATOR LEVER SET

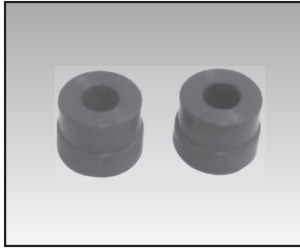

**PV0382** 80 DUROMETER FLAP DAMPER

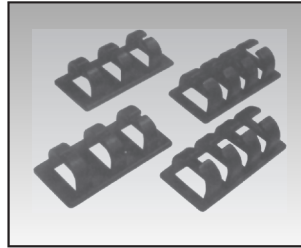

**PV0384** WIRE CLAMP

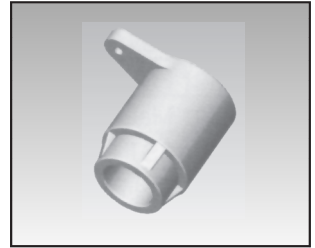

**PV0387** THROTTLE LEVER

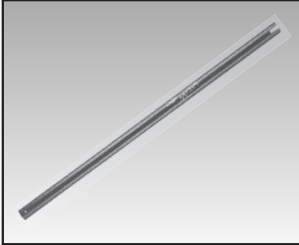

**PV0390** CARBON TAIL BOOM

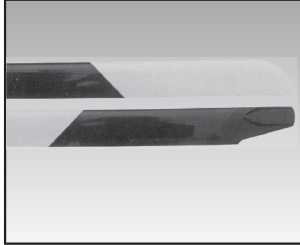

**3827** 600mm CARBON FIBER ROTOR BLADES

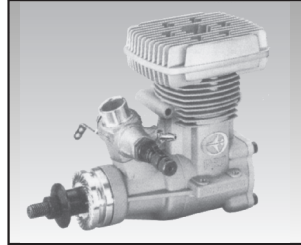

**9605** PRO-50H ENGINE

-----

-----

-----

-----

-----

-----

-----

-----

-----

-----

-----

-----

-----

-----

-----

-----

-----

-----

-----

-----

-----

-----

-----

-----

-----

-----

Parts No.	Description	Item No.	Description	quantity	Reference Assemble Step
AK0004	Flybar Seesaw	BK0004	Flybar Seesaw Hub	1	11
AK0029	Main Shaft	BK0029	Main Shaft	1	9
AK0148	85T Main Spur Gear	BK0148	85T Main Spur Gear	1	4
AK0174	Tail Drive Belt	BK0174	Tail Drive Belt	1	14
AV0052	Tail Idel Pulley Assy.	BV0052	Tail Idel Pulley	1	13
AV0143	Cooling Fan Assy.	BV0143	Cooling Fan Assy.	1	8
PV0002	Flybar Arm	BK0002	Flybar Control Arm	2	11
		BK0005	Flybar Arm Bushing	2	11
		BK0075	Linkage Ball	2	11
		HME4-5B	Set Screw, M4x5	2	11
		HMJ2-10N	Selftapping Screw, M2x10	2	11
PV0004	Mixing Lever	BK0006	Mixing Lever	2	11
		BK0075	Linkage Ball	4	11
		BK0076	Collar (dxD4xL10)	2	11
		BK0088	Flat Washer	2	11
		HMC3-14B	Socket Screw, M3x14	2	11
		HMJ2-10N	Selftapping Screw, M2x10	4	11
PV0005	Flybar Control Rod	BK0007	Flybar Control Rod	2	11
PV0008	Flybar Rod	BK0010	Flybar Rod	2	11
PV0011	Washout Set	BK0014	Washout Base	1	5
		BK0015	Flybar Control Lever	1	5
		BK0016	Washout Linkage	2	5
		BK0075	Link Ball	2	5
		BK0077	Collar (d3xD4xL6)	2	5
		BK0079	Pin	2	5
		HMC3-10B	Socket Screw, M2x10	2	5
		HMJ2-10N	Selftapping Screw, M2x10	2	5
PV0012	Pitch Control Arm	BK0017	Pitch Control Arm	1	6
		BK0075	Link Ball	1	6
		BK0078	Collar (d3xD4xL4)	2	6
		HMJ2-10N	Selftapping Screw, M2x10	1	6
		HMJ3-22B	Selftapping Screw, M3x22	1	6
		HSE3-12B	Selftapping Screw, M3x12	1	6
PV0013	Elevator Arm	BK0018	Elevator Control Arm	1	6
		BK0019	Elevator Arm Parallel Lever	1	6
		BK0020	Elevator Arm Shaft	1	6
		BK0023	Elevator Arm Linkage	2	6
		BK0075	Linkage Ball	1	6
		BK0084	Pin (D2xL23)	2	6
		HMJ2-10N	Selftapping Screw, M2x10	1	6
		HSE3-18B	Selftapping Screw, M3x18	2	6
PV0014	Elevator Lever	BK0021	Elevator Control Lever	1	6
		BK0075	Linkage Ball	2	6
		BK0076	Collar (d3xD4xL10)	1	6
		BK0088	Flat Washer	1	6
		HMJ2-14N	Selftapping Screw, M2x14	1	6
PV0015	Aileron Lever	BK0022	Aileron Control Lever	2	6
		BK0075	Linkage Ball	4	6
		BK0076	Collar (d3xD4xL10)	2	6
		HMJ2-10N	Selftapping Screw, M2x10	4	6
		HSE3-18B	Selftapping Screw, M3x18	2	6
PV0016	Tail Pitch Control Lever	BK0024	Tail Pitch Control Lever	1	13
		BK0075	Linkage Ball	1	13



Parts No.	Description	Item No.	Description	quantity	Reference Assemble Step
		BK0076	Collar (d3xD4xL10)	1	13
		BK0088	Flat Washer	1	13
		HMJ2-8N	Selftapping Screw, M2x8	1	13
		HSE3-18B	Selftapping Screw, M3x18	1	13
PV0017	Tail Pitch Slider	BK0025	Tail Pitch Control Fork	1	13
		BK0026	Tail Pitch Control Linkage	2	13
		BK0027	Tail Pitch Control Slider	1	13
		BK0028	Tail Pitch Control Slide Bushing	1	13
		BK0075	Linkage Ball	1	13
		BK0082	Collar, d2xD3xL4	2	13
		BK0083	Pin, D2xL9	2	13
		HMF2-8N	Screw, M2x8	1	13
		HSE2-10B	Selftapping Screw, M2x10	2	13
PV0018	Main Shaft Lock Ring	BK0030	Main Shaft Lock Ring	1	7
		HME4-5B	Set Screw, M4x5	2	7
PV0019	One Way Clutch	BV0033	One Way Clutch Housing Set	1	4
		HMV3-12	Socket Screw, M3x12	4	4
PV0020	One Way Clutch Shaft	BK0034	One Way Clutch Shaft	1	4
		HMC3-20B	Socket Screw, M3x20	1	4
		HMM3Z	Lock Nut, M3	1	4
		HMQ14	Retaining Ring, Ø14	2	4
PV0021	Guide Pulley Assy.	BV0035	Guide Pulley	1	3
		BK0036	Pulley Collar	2	3
		BK0081	Pin, D13xL18	1	3
PV0027	Tail Case	BK0046	Tail Unit Housing (L)	1	14
		BK0047	Tail Unit Housing (R)	1	13
		HMC3-20B	Socket Screw, M3x20	4	14
		HMC3-25B	Socket Screw, M3x25	2	14
		HMM3Z	Lock Nut, M3	6	14
PV0029	Tail Pulley Set	BK0050	Tail Pulley Set	1	13
		BK0051	Tail Pulley Flange	1	13
		BK0414	Pin, D2xL12	1	13
		HME3-4B	Set Screw, M3x4	1	13
PV0030	Tail Rotor Shaft	BK0053	Tail Rotor Shaft	1	13
		BK0414	Pin, D2xL12	1	13
		HME3-4B	Set Screw, M3x4	1	13
PV0033	Servo Frame	BK0057	Servo Frame	1	3
		HMJ3-12B	Selftapping Screw, M3x12	6	3
PV0035	Landing Skid Set	BK0064	Skid	2	10
		BK0065	Skid Cap	4	10
		BK0066	Skid Brace	2	10
		HMJ3-18B	Selftapping Screw, M3x18	4	10
		HME4-5B	Set Screw, M4x5	4	10
PV0036	Flybar Paddle	BK0067	Flybar Paddle	2	11
		HME3-10B	Set Screw, M3x10	2	11
PV0037	Tail Rotor Blade	BK0068	Tail Rotor Blade	2	15
PV0038	Tail Fin	BK0069	Stabilizer Fin	1	14
		BK0070	Stabilizer Fin Bracket	1	14
		BK0071	Vertical Fin	1	14
		HSE3-12B	Selftapping Screw, M3x12	2	14
PV0040	Double Link	BV0085	Double Link	2	11
PV0041	Ball Link	BK0086	Ball Link	12	12
PV0044	Link Rod	BK0092	LinkageRod (L=30)	3	17

Parts No.	Description	Item No.	Description	quantity	Reference Assemble Step
		BK0093	Linkage Rod (L=45)	3	17
		BK0094	Linkage Rod (L=60)	2	17
		BK0095	Linkage Rod (L=76)	2	17
PV0048	Pitch Frame/ Rotor Hub Seesaw Brg.	HMV840ZZ	Bearing, d4xD8xW3	2	6
PV0049	Seesaw Brg.	HMV830ZZ	Bearing, d4xD8xW4	2	11
PV0051	Leaver Brg.	HMV740ZZ	Bearing, d4xD7xW2.5	4	5
PV0052	Tail Slider Brg.	HMV1060	Bearing, d6xD10xW3	2	13
PV0053	Rotor Bolt.	HMC4-27B	Cap Screw, M4x27	2	20
		HMM4Z	Lock Nut, M4	2	20
PV0054	Servo Mounting Plate	BK0104	Servo Mounting Plate	10	16
PV0056	Frame Spacer (L)	BK0058	Frame Spacer (L)	5	3
PV0057	Frame Spacer (S)	BK0059	Frame Spacer (S)	10	3
PV0058	Link Ball	BK0075	Linkage Ball	12	5
PV0059	Tail Shaft Brg.	HMV1150	Bearing, d5xD11xW5	2	13
PV0060	Installation Set	BE1052	Antenna Tube	1	18
		BK0106	Double Side Tape	2	18
		BK0109	Rubber Band 5x3 20xT1	2	18
		HNI15	Hex Wrench 1.5mm	1	1
		HNI2	Hex Wrench 2mm	1	1
		HNI25	Hex Wrench 2.5mm	1	1
		HNI3	Hex Wrench 3mm	1	1
		HNJ-1	Tie Band 2.5x100	3	8
PV0062	Body Mount Rubber Grommet	BK0102	Body Mount Rubber	5	19
PV0092	Swash Plate	BV0092	Metal Swash Plate	1	7
PV0093	Main Shaft Bearing	HMV1680	Bearing, d8xD16xW5	1	2
		HMV6800	Bearing, d10xD19xW5	2	6
PV0107	Engine Mount (.50)	BK0087	Washer	4	9
		BK0144	Engine Mount	1	9
		BK0179	Engine Mount Spacer	2	9
		HMC3-14	Socket Screw	8	9
PV0109	High Performance Muffler (.46-.50)	BA1579	Muffler Gasket	1	9
		MV0172	Muffler	1	9
		HMC3-35B	Socket Screw	2	9
		HMT3B	Spring Washer	2	9
PV0118	Main Rotor Blades	BV0176	Main Rotor Blade	1	20
PV0148	Tail Rotor Grip	BK0302-1	Tail Pitch Housing (A)	2	13
		BK0303-1	Tail Pitch Housing (B)	2	13
		HMC2610B	Socket Screw, M2.6x10	4	13
		HMM26B	Lock Nut, M2.6	4	13
		HMC3-14B	Socket Screw, M3x14	2	13
		HMM3B	Lock Nut, M3	2	13
PV0151	Tail Rotor Hub	BK0307	Tail Rotor Hub	1	13
		HME3-18B	Set Screw, M3x18	2	13
		HMM3B	Lock Nut, M3	2	13
PV0200	Tail Rotor Brg.	HMV1050	Bearing, d5xD10xW5	4	13
PV0203	Starter Shaft Brg.	HMV696Z	Bearing, d6xD15xW5	2	3
PV0267	Loctite #242			1	
PV0268	Loctite #262			1	
PV0270	Plastic Gear Grease			1	
PV0279	Tail Rod Guide	BK0091	Rod Guide	3	14
PV0311	Header Tank	BK0087	Washer	1	15
		BK0102	Rubber Grommet	1	15

Parts No.	Description	Item No.	Description	quantity	Reference Assemble Step
		BK0506	Header Tank Support	1	15
		BK0502	Header Tank	1	15
		HMC3-14B	Socket Screw	1	15
PV0326	Carbon Graphite Base Plate	BK0525	Carbon Graphite Base Plate	1	10
PV0329	Tail Support	BK0447	Tail Support Rod End	4	14
		BK0524	Tail Support Rod	2	14
		HMJ2-8N	Selftapping Screw, M2x8	4	14
PV0353	Main Rotor Grip	BK0075	Linkage Ball	2	11
		BK0596	Main Pitch Housing	2	11
		HMJ2-10N	Selftapping Screw, M2x10	2	11
PV0354	Main Rotor Hub	BK0587	Main Rotor Pin	1	11
		BK0616	Socket Screw, M3x20	1	12
		BV0595	Main Rotor Hub	1	11
		HMM3Z	Lock Nut, M3	1	12
PV0355	Spindle	BK0581	Flap Collar	2	11
		BK0583	Feathering Shaft	1	11
		BK0435	Washer, d4xD11x1.7	2	11
		HMC4-8B	Socket Screw, M4x8	2	11
PV0358	Clutch Bell	BV0591	Clutch Bell Set	1	2
PV0359	Clutch	BK0170	Shim	1	8
		BV0589	Clutch Bell Set	1	8
		HMC3-10B	Socket Screw, M3x10	2	8
PV0360	Starter Shaft	BK0592	Starter Shaft	1	3
		HME4-5B	Set Screw, M4x5	2	3
		HMS5	E-Clip	1	3
PV0361	Starter Coupling	BK0594	Starter Coupling	1	3
		HME4-5B	Set Screw, M4x5	2	3
PV0362	Main Frame Set	BK0058	Frame Spacer (L)	4	3
		BK0059	Frame Spacer (S)	8	3
		BK0599	Main Frame Left Side	1	3
		BK0600	Main Frame Right Side	1	3
		HMC3-20B	Socket Screw, M3x20	4	15
		HMM3Z	Lock Nut, M3	4	15
		HSE3-12B	Selftapping Screw, M3x12	24	3
PV0363	Fuel Tank	BV0605	Fuel Tank Set	1	1
PV0364	Body	BK0098	Body Clip A	1	19
		BK0099	Body Clip B	1	19
		BK0102	Rubber Grommet	2	19
		BK0611	Body	1	19
		BK0612	Canopy	1	19
		HSE3-12B	Selftapping Screw, M3x12	2	19
PV0365	Thrust Brg.	HMX0612	Thrust Bearing	2	11
PV0368	Clutch Liner	BK0590	Clutch Liner	2	2
PV0369	Canopy Only	BK0612	Canopy	1	19
		HMJ2-6B	Selftapping Screw, M2x6	6	19
PV0370	Body Only	BK0098	Body Clip A	1	19
		BK0099	Body Clip A	1	19
		BK0611	Body	1	19
		BK0102	Rubber Grommet	2	19
		HSE3-12B	Selftapping Screw, M3x12	2	19
PV0372	Thrust Collar	BK0584	Thrust Collar	2	11
PV0373	Clutch Bell Brg.	HMV1260Y	Bearing, d6xD12xW4	2	2
PV0374	Feathering Brg.	HMV1260Z	Bearing, d6xD13xW5	2	11

Parts No.	Description	Item No.	Description	quantity	Reference Assemble Step
PV0375	Body Retaining Set	BK0626	Body Mount Nut	2	19
		HME3-18B	M3x18 Set Screw	2	19
PV0379	Auto Rotation Pully	BK0610	Auto Rotation Pully	1	4
		HMC3-8B	Socket Screw	4	4
PV0380	Pinion Gear (10T)	BK0624	Drive Gear	1	2
PV0389	Decal	JV0110	Decal	1	19
PV0392	Tail Control Rod	BK0086	Ball Link	2	14
		BK0105	Tail Control Rod Joint	1	16
		BK100-1	Push Pull Rod-1	1	16
		BK0175	Push Pull Rod-2	1	14
		HME4-5B	Set Screw, M4x5	2	14
PV0393	R50 Tail Boom	BK0173	Tail Boom	1	14
PV0088	Screw Bag	HMF2-6N	Screw, M2x6	6	
		HMF2-8N	Screw, M2x8	6	
		HMJ2-10N	Selftapping Screw, M2x10	6	
		HMJ2-14N	Selftapping Screw, M2x14	6	
		HMJ2-6B	Selftapping Screw, M2x6	6	
		HMJ3-22B	Selftapping Screw, M3x22	6	
		HSE2-10B	Selftapping Screw, M2x10	6	
		HSE2612N	Selftapping Screw, M2.6x12	6	
		HSE3-12B	Selftapping Screw, M3x12	6	
		HSE3-18B	Selftapping Screw, M3x18	6	
		HSE3-5B	Selftapping Screw, M3x5	6	
PV0089	Screw Bag	BK0616	Socket Screw, M3x20	2	
		HMC3-10B	Socket Screw, M3x10	6	
		HMC3-12B	Socket Screw, M3x12	6	
		HMC3-14B	Socket Screw, M3x14	6	
		HMC3-20B	Socket Screw, M3x20	6	
		HMC3-25B	Socket Screw, M3x25	6	
		HMC3-32B	Socket Screw, M3x32	6	
		HMC3-8B	Socket Screw, M3x8	6	
		HME3-10B	Set Screw, M3x10	6	
		HME3-18B	Set Screw, M3x18	6	
		HME4-5B	Set Screw, M4x5	6	